

THE SOUND THAT VORTICES WITHIN VORTICES MAKE

Georgios H. Vatistas

Dept. of Mechanical and Industrial Engineering, Concordia University, Montreal, Quebec, Canada, H3G 1M8

1. INTRODUCTION

Vortices being interwoven into the fabric of fluid mechanics appear in the majority of naturally occurring and industrial flows. In technology these are either produced deliberately to accomplish the task, improve the function of devices, or emerge as a parasitic bi-product of fluid motion. As they are transported by the main flow, they may deform, impinge on solid surfaces, or interact with other vortices producing sound. Because of this they are often called the voice of fluid motion. In the greater part of situations their presence in the flow produce vibrations and noise and the designer strives to suppress them.

Vortex-body interaction has been in the forefront of aeroacoustic research for many years. Most of the contributions consider vortices of the zero-circulation Taylor's type. Much less is however known about the noise generated by deforming intense vortices. Recently, several contributions¹⁻³ appeared in the technical literature with respect to the acoustics produced by non-zero circulation, intense, concentrated vortices (most of the vorticity resides within the core) like the $n = 2$ model⁴.

Another important vortex manifestation that appears to have been neglected in aeroacoustical research is noise produced by interacting satellite vortices that are known to spawn inside a parent vortex. The present paper focuses on this feature.

Humans have noticed since the ancient times that domesticated and wild animals change dramatically their behavior in front of an impending disaster, such as severe storms like hurricanes and tornadoes. Is subaudible sound the messenger of the imminent danger? In 1996, Bedard from NOAA Boulder Colorado, while assessing some sensitive microphones detected a low frequency sound emanating from an unknown source. With the aid of radar, he located the presence of some tornadoes in the area. Tracking them down he discovered that their location appeared to correspond to the site of the detected infrasound. In a relatively recent article⁵, Bedard has attributed the unusual acoustical manifestation to waves produced inside the vortex cores. In antithesis to the ~ 60 km range of a tornado-warning radar system, the detection limit via the new infrasound device could now exceed 100 km. Alike to the noise produced in vortex chambers the experiments performed in a laboratory simulated tornado revealed that the sounds produced were pretty irritating. Is this sound quality that makes the animals to be agitated and aware of the impending danger?

The aim of this paper is to brief the acoustical community about some new developments in vortex dynamics (particularly on satellite vortices/waves inside a parent vortex) that are relevant to the sound produced by intense concentrated eddies.

2. VORTICES/WAVES

2.1 The polygonal core shapes of whirlpools

Past experimental studies⁶ have shown that under prevailing conditions, waves on the free surface of a liquid vortex produced in the apparatus shown in Fig. 1, exhibit the fundamental characteristics of Kelvin's equilibrium patterns. The rotary motion imparted to the fluid by the disk, generates a centrifugal force field, which pushes the liquid towards the container's wall. The receding liquid exposes part of the surface of the disk to air whereby, the line of intersection between the surfaces of the solid disk, the liquid, and air outlines the core shape. In order to bring the patterns into relief, the liquid was colored with a blue water-soluble dye. For very low rotational disk speeds it is expected that the water vortex core remains circular expanding and contracting in time ($n = 0$, breathing mode). Increasing its rotation, the vortex transfers into another state characterized by a precessing circular core ($n = 1$). A further increase of disk speed (ω_d) yields progressively cores with elliptical ($n = 2$), triangular ($n = 3$), square ($n = 4$), pentagonal ($n = 5$), and hexagonal ($n = 6$) shapes, see Fig. 2. No heptagonal shape was formed. Since the interval of

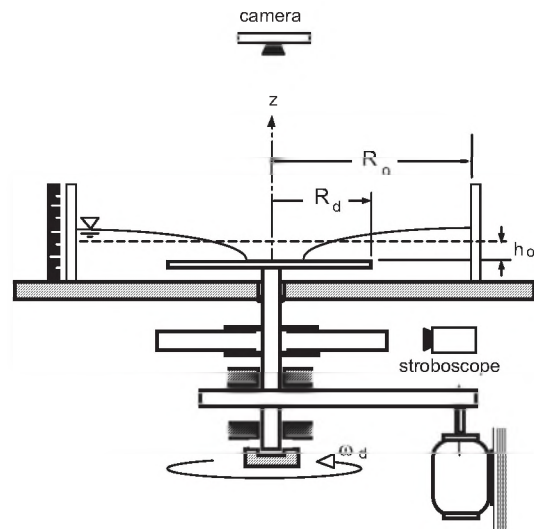

Figure 1. The experimental apparatus.

endurance of the stationary states decreases with n , if $n = 7$ exists in theory it must be critically stable. As the disk speed increases well beyond $n = 6$ amplification of dynamical noise will eventually wipe out the sharp spectral peaks.

The source of the waves appearing on the liquid interface has been now attributed to the presence of revolving satellite vortices, which give the event a dual wave/vortex nature.

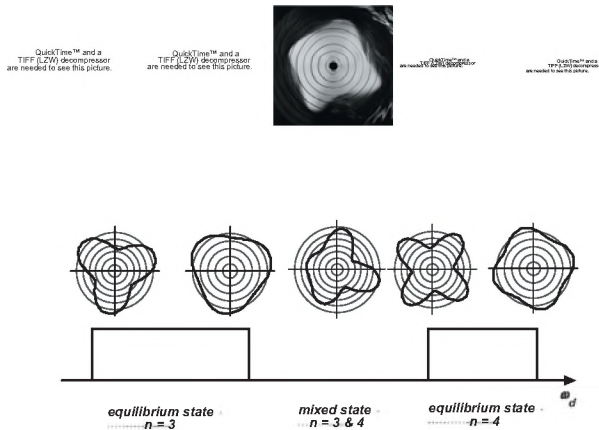

Figure 2. Spectrum of core patterns.

2.2 The solitron

The solitary wave in rotation (or solitron) experiments were conducted in a transparent cylindrical reservoir having a circular outlet, fixed on the bottom plate. The wave of Fig. 3 appeared as the liquid level dropped to a specific height. Among some other interesting things we now find that the evolution of the cylindrical soliton depends strongly on the original residual vorticity of the liquid inside the tank. Furthermore, the height of the single interfacial wave increases if a jolt is applied to the container along the lateral direction prior to the wave development.

QuickTime™ and a
TIFF (LZW) decompressor
are needed to see this picture.

Figure 3. The solitary wave.

2.2 The resonating vortex

Our tests have also revealed that in tall vortices and for certain disk speeds a spectacular episode appeared. Initially the core was relatively calm having the expected inverted bell-like shape and an almost circular interfacial surface in every elevation. Past this stage, the vortex started to form in time polygons of different shapes on the disk surface in an indiscernible manner but giving the impression that it was searching in vain to find a stationary state. Failing to do so, a good portion of the core transformed into an elliptical cross-sectional form, and the liquid surface began to undulate. The minor axis of the ellipse was then shortened and the major was elongated while the free-surface sloshing behavior intensified. Finally, the free liquid surface was pinched near the center of rotation forming two vortices. Subsequently, the eddy was destroyed and the liquid interface returned to its initial calm condition. This phenomenon was repeated without any external stimulus. These experiments reveal that the phenomenon is highly sensitive to spin history, see Fig. 4. Given the disk speed the

sloshing only happens within a specific interval of initial liquid heights.

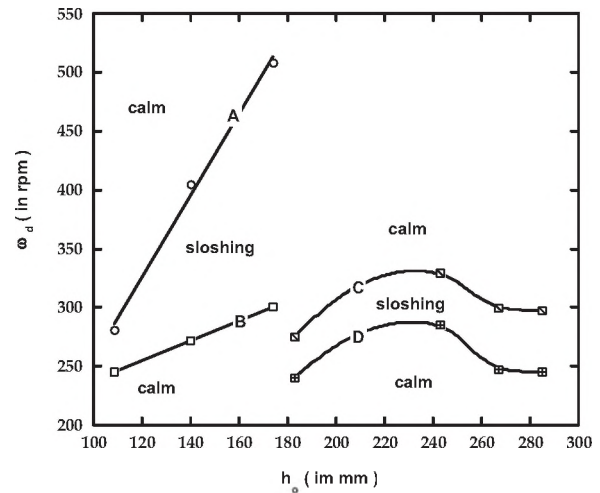

Figure 4. Spectrum of resonance.

3. CONCLUSIONS

Several vortex/wave phenomena, pertinent to the sound produced by intense, concentrated, vortices, were described. Hopefully, this presentation will capture the interest of the acoustical community so that by incorporating these effects into the current aeroacoustical simulations, it will yield an adequate insight into a phenomenon, which is of significance to science and technology.

REFERENCES

- Povitsky, A., Zheng, T.H., and Vatisias, G.H. "Effect of vortex profile on sound generation in a non-uniform flow", *Math. Comput. Simulat.*, **65** (4-5): 447-468 (2004).
- Casey L. Burley, et al. "Rotor wake vortex definition—evaluation of 3-C PIV results of the HART-II study", *Aeroacoustics*, **5** (1): 1-38 (2006).
- Zheng, T. H., Vatisias, G.H., and Povitsky, A. "Sound generation by a street of vortices in a nonuniform flow", *Phys. Fluids* **19**: 037103 (2007).
- Vatisias, G.H., Kozel, V. and Minh, W. "A Simpler model for concentrated vortices" *Exp. Fluids*, **11** (1): 73-76 (1991).
- Bedard Jr., A. J. "Low-Frequency Atmospheric Acoustic Energy Associated with Vortices Produced by Thunderstorms", *Month. Weather Rev.*, **133**: 241- 263 (2005).
- Vatisias, G.H. "A Note on Liquid Vortex Sloshing and Kelvin's Equilibria". *J. Fluid Mech.* **217**, 241-248 (1990).