

A NEW APPROACH TO BUILDING ACOUSTICS REGULATION IN CANADA

David Quirt ¹ and Berndt Zeitler ²

¹ 1949 Mulberry Crescent, Ottawa K1J8J8, Canada.

² National Research Council Canada, Ottawa, K1A 0R6, Canada

1 Introduction

A new approach to controlling sound transmission between adjoining units in residential buildings is proposed in the 2015 edition of the National Building Code of Canada (NBCC). The design objective is changing from a minimum STC for the wall or floor/ceiling assembly separating adjacent units to a minimum Apparent Sound Transmission Class (ASTC), which includes transmission of both direct and flanking sound. The design approach uses data from ASTM E90 laboratory measurements of direct transmission through wall or floor/ceiling assemblies together with flanking transmission data conforming to ISO 10848 as inputs to calculation procedures based on ISO 15712-1. This paper focuses on explaining the technical intent and form of the proposed new NBCC requirements.

2 The New Minimum Requirement

The minimum requirement changes from STC 50 for the separating assembly to ASTC 47 for sound transmission (including flanking transmission) between adjoining dwelling units. This limit was chosen to avoid significant increase in average cost of construction, while discouraging the use of construction details that seriously degrade system performance.

This should be recognized as a regulatory minimum, which many occupants would not consider to be satisfactory sound insulation. Many builders try to provide much better noise control. The supporting publications and calculation tools described in a companion paper ¹ provide the resources to achieve this via systematic design.

3 Three Paths to show Compliance

There are three paths to establish compliance with the Code requirement. Rather than reproduce the requirements in Code language, the design approach is explained here in technical terms. For a more detailed explanation see NRC report RR-331 ² which is also referenced in the NBCC.

3.1 Show Compliance via Field Testing

A design is acceptable if its details replicate a system (separating assembly, flanking constructions, and junctions) that has been shown to provide ASTC 47 or better in field testing according to ASTM E336.

3.2 Show Compliance via Prescriptive Method

The section of the NBCC dealing with houses and small buildings provides a set of prescriptive details that are

deemed to satisfy the ASTC requirement. For a limited set of separating constructions whose STC and fire resistance ratings are listed in tables in the NBCC, specific prescriptive requirements are provided for common generic flanking assemblies connected to the separating assembly at its edges.

An example for a generic wood-stud separating wall combined with wood-framed floor, ceiling, and side wall flanking assemblies is presented with simplified phrasing in Fig. 1 to indicate the nature of a typical set of prescriptive requirements.

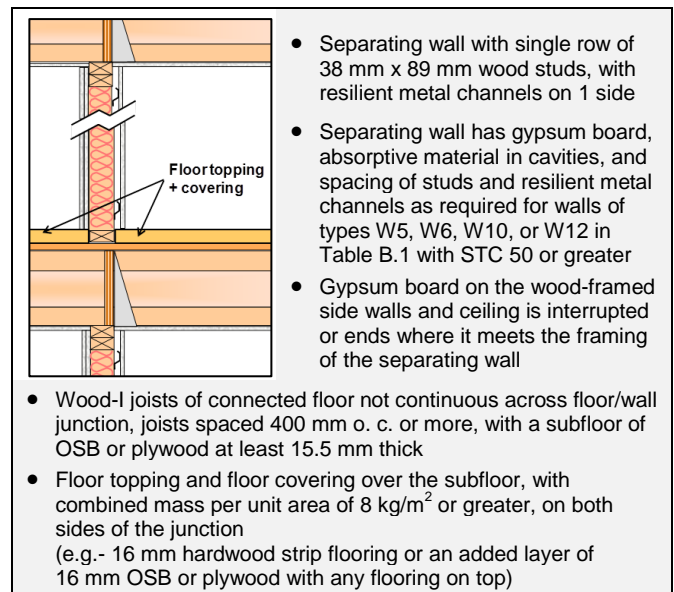

Figure 1: Prescriptive details required to meet design objective (ASTC=47 or greater) between side-by-side spaces, for a specified combination of separating wall and attached flanking assemblies

The prescriptive requirements were based on calculations for sets of single path data tested according to ISO 10848, for typical combinations of closely-comparable connected assemblies. Construction details such as fastening gypsum board to the framing of flanking surfaces were assumed to be the worst-case variant consistent with approved practice, and a minimum improvement was identified for the most significant flanking path – providing a heavier floor surface in this case.

An appendix suggests some variants which could improve performance (such as choosing surfaces for the separating wall to increase Direct STC, or mounting the gypsum board ceiling on resilient metal channels) in order of their usefulness, but this prescriptive process gives no indication of the resulting ASTC.

3.3 Show Compliance via Design Method

The new Code requirements and ISO 15712-1 approach predicting the sound transmission from the same basic concept – combining the sound power transmitted directly through the separating assembly with the flanking transmission via first-order flanking paths at each edge of the separating assembly. To discuss this, it is useful to introduce the convention used in ISO 15712-1 for labelling the transmission paths, as illustrated in Figure 2.

Consider transmission from a source room at the left to the receiving room beside it. Each transmission path involves one surface in the source room (denoted by a capital letter) and one in the receive room (lower case). **D**irect transmission through the separating wall is path **Dd**. For each edge of the separating assembly there are three 1st-order flanking paths, each involving a surface in the source room and one in the receiving room, that connect at this edge: **Ff** from **f**lanking surface **F** to **f**lanking surface **f**, **Df** from **d**irect surface **D** to **f**lanking surface **f**, and **Fd** from **f**lanking surface **F** to **d**irect surface **d** in the receiving room.

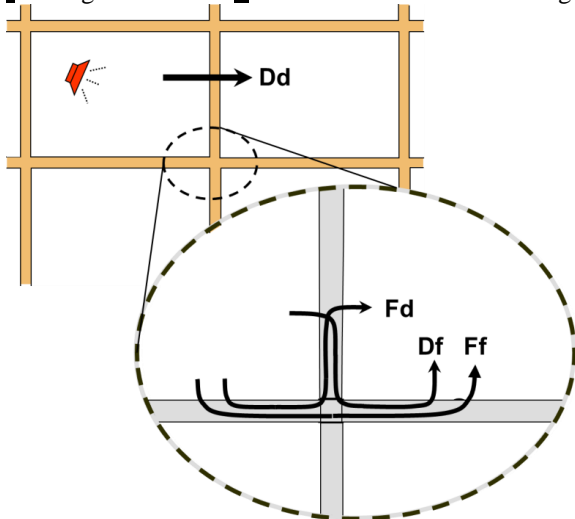

Figure 2: Labelling convention used in ISO 15712-1 for direct and flanking transmission paths

Note that “**F**” and “**f**” denote **f**lanking surfaces, whereas “**D**” and “**d**” denote the surface for **d**irect transmission, i.e. - the surface of the separating assembly. Each of these labels may apply to either wall or floor/ceiling assemblies, depending on orientation of the room pair.

In Canada, building elements (walls, etc.) are normally tested according to ASTM E90 and the Code requirements are given in terms of STC or ASTC ratings determined from the 1/3-octave test data, following the procedure in ASTM E413. Merging this ASTM context familiar to the building industry and to regulators with the ISO procedures now being added to the Code, requires new terminology, so “direct transmission loss” and “flanking transmission loss” have been introduced to provide consistency with ASTM terminology, but match the function of the direct and flanking sound reduction index, as defined in ISO 15712-1.

Section 4.1 of ISO 15712-1 defines a process to calculate apparent sound transmission by combining the sound power transmitted via the direct path and the twelve

first-order flanking paths (See Figure 2). Equation 14 of ISO 15712-1 is recast here with different grouping of the paths, assuming rectangular room geometry and neglecting paths due to leaks, ducts, crawlspaces, etc., which should be controlled by normal good practice. The Apparent Sound Transmission Loss (ATL) between two rooms is the decibel expression of the sum of sound power due to Direct Sound Transmission Loss (TL_{Dd}) through the separating wall or floor element and the sound power due to Flanking Sound Transmission Loss contributions (TL_{Ff} , TL_{Fd} , and TL_{Df}) of the three flanking paths for every junction at the edges of the separating element:

$$ATL = -10 \lg \left(10^{-0.1 \cdot TL_{Dd}} + \sum_{edge=1}^4 (10^{-0.1 \cdot TL_{Ff}} + 10^{-0.1 \cdot TL_{Fd}} + 10^{-0.1 \cdot TL_{Df}}) \right)$$

This summation of transmitted sound power is valid for all building systems, but the remaining challenge is to find the right expressions to calculate the path transmission for the chosen building system and situation. The design procedure proposed for the NBCC constrains these choices, depending on the type of wall and floor constructions combined to form a complete building, as follows:

- **For heavy homogenous types of construction** such as concrete floors or concrete block walls, the NBCC design procedure determines the flanking sound transmission loss by either the Detailed or Simplified calculation procedures of ISO 15712-1. For input data, these calculations use sound transmission loss data (for the base wall and floor assemblies and for linings) measured according to ASTM E90.
- **For lightweight steel- or wood-framed assemblies**, the NBCC design procedure substitutes experimental flanking data (treating flanking sound reduction index determined using ISO 10848 as Flanking Transmission Loss) for values calculated with ISO 15712-1. Either a detailed calculation using 1/3-octave-band data or a simplified procedure using the corresponding single-number ratings is permitted.

In either case, the calculation combines the sound power due to direct and flanking transmission in the same way.

Conclusion

Re-focusing the noise control requirements of Canada’s building codes on the performance of the complete system should both avoid the worst designs and shift industry focus to optimizing the transmission paths that limit the ASTC.

References

- [1] I. Sabourin, B. Zeitler and J.D. Quirt, Supporting Better Noise Control in Canadian Buildings, *AWC 2014*
- [2] D. Quirt, B. Zeitler, S. Schoenwald, I. Sabourin, T. Nightingale, “RR-331: Guide to Calculating Airborne Sound Transmission in Buildings” *NRC Canada*, 2013.