

# canadian acoustics

# acoustique canadienne

Journal of the Canadian Acoustical Association - Revue de l'Association canadienne d'acoustique

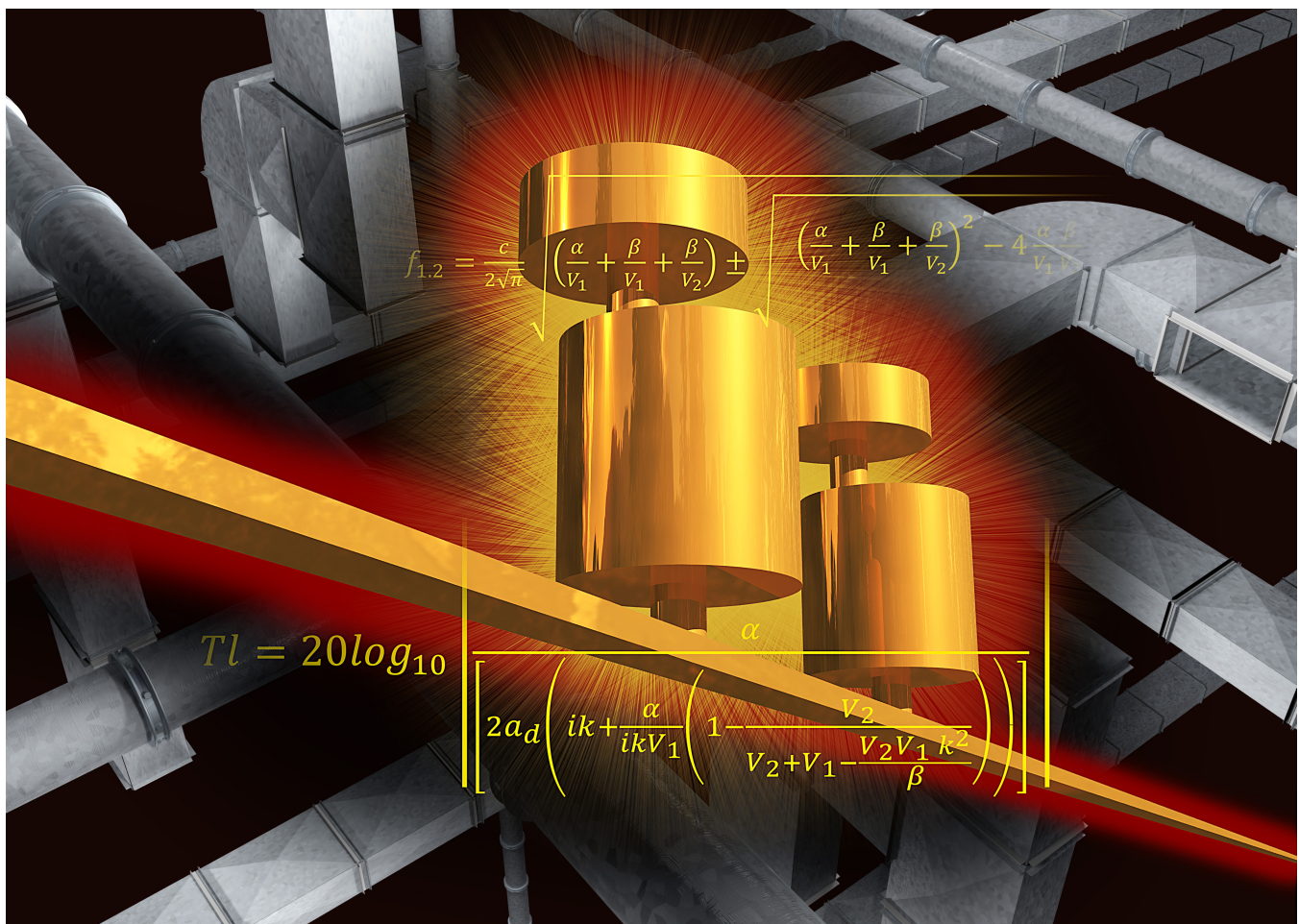
DECEMBER 2016

Volume 44 - - Number 4

DÉCEMBRE 2016

Volume 44 - - Numéro 4

EDITORIAL - ÉDITORIAL	2
GUEST EDITORIAL - ÉDITORIAL INVITÉ	4
ARCHITECTURAL ACOUSTICS - ACOUSTIQUE ARCHITECTURALE	6
ENGINEERING ACOUSTICS / NOISE CONTROL - GÉNIE ACOUSTIQUE / CONTRÔLE DU BRUIT	12
PROCEEDINGS OF THE ACOUSTICAL WEEK IN CANADA - ACTES DU CONGRÈS DE LA SEMAINE CANADIENNE D'ACOUSTIQUE	18
OTHER FEATURES - AUTRES RUBRIQUES	25



# canadian acoustics

Canadian Acoustical Association/Association  
Canadienne d'Acoustique P.B. 74068 Ottawa,  
Ontario, K1M 2H9

Canadian Acoustics publishes refereed articles and news items on all aspects of acoustics and vibration. Articles reporting new research or applications, as well as review or tutorial papers and shorter technical notes are welcomed, in English or in French. Submissions should be sent only through the journal online submission system. Complete instructions to authors concerning the required "camera-ready" manuscript are provided within the journal online submission system.

Canadian Acoustics is published four times a year - in March, June, September and December. This quarterly journal is free to individual members of the Canadian Acoustical Association (CAA) and institutional subscribers. Canadian Acoustics publishes refereed articles and news items on all aspects of acoustics and vibration. It also includes information on research, reviews, news, employment, new products, activities, discussions, etc. Papers reporting new results and applications, as well as review or tutorial papers and shorter research notes are welcomed, in English or in French. The Canadian Acoustical Association selected Paypal as its preferred system for the online payment of your subscription fees. Paypal supports a wide range of payment methods (Visa, Mastercard, Amex, Bank account, etc.) and does not require you to have already an account with them. If you still want to proceed with a manual payment of your subscription fee, please use the application form from the CAA website and send it along with your cheque or money order to the secretary of the Association (see address above). - Canadian Acoustical Association/Association Canadienne d'Acoustique P.B. 74068 Ottawa, Ontario K1M 2H9 Canada - - - secretary@caa-aca.ca - Dr. Roberto Racca

# acoustique canadienne

Association canadienne d'acoustique B.P. 74068  
Ottawa, Ontario, K1M 2H9

L'Acoustique Canadienne publie des articles arbitrés et des informations sur tous les aspects de l'acoustique et des vibrations. Les informations portent sur la recherche, les ouvrages sous forme de revues, les nouvelles, l'emploi, les nouveaux produits, les activités, etc. Des articles concernant des résultats inédits ou des applications ainsi que les articles de synthèse ou d'initiation, en français ou en anglais, sont les bienvenus.

Acoustique canadienne est publié quatre fois par an, en mars, juin, septembre et décembre. Cette revue trimestrielle est envoyée gratuitement aux membres individuels de l'Association canadienne d'acoustique (ACA) et aux abonnés institutionnels. L'Acoustique canadienne publie des articles arbitrés et des rubriques sur tous les aspects de l'acoustique et des vibrations. Ceci comprend la recherche, les recensions des travaux, les nouvelles, les offres d'emploi, les nouveaux produits, les activités, etc. Les articles concernant les résultats inédits ou les applications de l'acoustique ainsi que les articles de synthèse, les tutoriels et les exposées techniques, en français ou en anglais, sont les bienvenus. L'Association canadienne d'acoustique a sélectionné Paypal comme solution pratique pour le paiement en ligne de vos frais d'abonnement. Paypal prend en charge un large éventail de méthodes de paiement (Visa, Mastercard, Amex, compte bancaire, etc) et ne nécessite pas que vous ayez déjà un compte avec eux. Si vous désirez procéder à un paiement par chèque de votre abonnement, merci d'utiliser le formulaire d'adhésion du site de l'ACA et de retourner ce dernier avec votre chèque ou mandat au secrétaire de l'association (voir adresse ci-dessus). - Canadian Acoustical Association/Association Canadienne d'Acoustique P.B. 74068 Ottawa, Ontario K1M 2H9 Canada - - - secretary@caa-aca.ca - Dr. Roberto Racca

---

## EDITOR-IN-CHIEF - RÉDACTEUR EN CHEF

**Jérémie Voix**  
ÉTS, Université du Québec  
editor@caa-aca.ca

## DEPUTY EDITOR - RÉDACTEUR EN CHEF AD- JOINT

**Umberto Berardi**  
Ryerson University  
deputy-editor@caa-aca.ca

## COPYEDITOR - RELECTEUR-RÉVISEUR

**Cécile Le Cocq**  
École de technologie supérieure  
copyeditor@caa-aca.ca

---

## ADVISORY BOARD - COMITÉ AVISEUR

**Jérémie Voix**  
ÉTS, Université du Québec

**Frank A. Russo**  
Ryerson University

**Ramani Ramakrishnan**  
Ryerson University

**Bryan Gick**  
University of British Columbia

## ADVERTISING EDITOR - RÉDACTEUR PUBLICITÉS

**Bernard Feder**  
HGC Engineering  
advertisement@caa-aca.ca

# Contents - Table des matières

---

<b>EDITORIAL - ÉDITORIAL</b>	<b>2</b>
<b>GUEST EDITORIAL - ÉDITORIAL INVITÉ</b>	<b>4</b>
President's Message	
<i>Frank A. Russo</i>	4
<b>ARCHITECTURAL ACOUSTICS - ACOUSTIQUE ARCHITECTURALE</b>	<b>6</b>
Using the Parameters of Definition D50 and Reverberation Time RT to Investigate the Acoustic Quality of Classrooms	
<i>Samuel Ansay, Paulo Henrique Trombetta Zannin</i>	6
<b>ENGINEERING ACOUSTICS / NOISE CONTROL - GÉNIE ACOUSTIQUE / CONTRÔLE DU BRUIT</b>	<b>12</b>
A Comparative Study Between Different Helmholtz Resonator Systems	
<i>Md. Amin Mahmud, Md. Shahriar Islam, Md. Zahid Hossain, Mir Md. Maruf Morshed</i>	12
<b>PROCEEDINGS OF THE ACOUSTICAL WEEK IN CANADA - ACTES DU CONGRÈS DE LA SEMAINE CANADIENNE D'ACOUSTIQUE</b>	<b>18</b>
Intrinsic and Extrinsic Portions of Soft Palate Muscles in Velopharyngeal and Oropharyngeal Constriction: A 3D Modeling Study	
<i>Peter Anderson, Sidney Fels, Ian Stavness, Bryan Gick</i>	18
<b>OTHER FEATURES - AUTRES RUBRIQUES</b>	<b>25</b>
2016 CAA Awards Winners - Récipiendaires des prix ACA 2016	25
CAA Prizes Announcement for 2017 - Annonce des prix ACA 2017	27
Post-conference report on AWC 2016 - Rapport post-conférence AWC 2016	29
AWC 2017 Guelph Conference Announcement and Call for Papers - Appel à communication - Semaine canadienne de l'acoustique AWC2017 à Guelph	37
Call for papers - Special Halifax regional journal issue - Appel à communications - Numéro spécial pour la région d'Halifax	43
Minutes from the CSA Standards Meeting 2016 - Compte rendu rencontre sur normalisation ACNOR 2016	45
Minutes of the 2016 CAA Board of Directors Meeting - Compte rendu de la réunion du conseil d'administration 2016 de l'ACA	51
Minutes of 2016 CAA Annual General Meeting - Compte rendu de l'assemblée générale annuelle 2016 de l'ACA	55
CAA Announcements - Annonces de l'ACA	59
2016 CAA Membership Directory - Annuaire des membres de l'ACA 2016	62



## Encore un appel à l'action...

Ce numéro de décembre nous permet de réaliser les nombreux accomplissements des 12 derniers mois à l'Association canadienne d'acoustique, et ceux-ci sont résumés en page 55 dans le compte-rendu de l'assemblée générale des membres rédigé par notre secrétaire exécutif, Roberto Racca. C'est également le moment de souhaiter la bienvenue à notre rédacteur en Sciences de la parole, le professeur Mickael Kieffe en remplacement de la professeure Linda Polka et de reconnaître le formidable travail accompli par notre comité éditorial, présenté en page 21. Les normes scientifiques élevées maintenues par la revue *Acoustique canadienne* doivent beaucoup au dévouement constant des réviseurs de la revue, qui donnent généreusement de leur temps et de leur expertise. C'est un plaisir de rendre hommage à cette contribution en reconnaissant ceux, listés à la page 23, qui ont participé au processus d'examen en 2016.

Suite au succès remporté par les deux premiers numéros portant sur des sujets régionaux de la grande région de Montréal et de Toronto, ce sera donc la grande région de Halifax qui sera l'objet du numéro de juin 2017. Assurez-vous d'y contribuer, les détails sont à la page 43, car ces numéros devraient rapidement devenir le « Who's Who » en acoustique au sein des principales villes canadiennes.

Inscrivez également dans vos agendas la prochaine Semaine canadienne d'acoustique (AWC17), qui aura lieu du 11 au 13 octobre 2017 à Guelph (ON), tel que mentionné dans l'appel à communications à la page 37.

## Yet another call for action...

This December issue gives us an opportunity to recognize the many accomplishments that took place over the past 12 months for the Canadian Acoustical Association, and that you will see highlighted in the report from the AGM prepared by our Executive Secretary, Dr. Roberto Racca and presented on page 55. It is also now time to welcome a new Associate Editor, Prof. Mickael Kieffe in replacement of Linda Polka for the Speech Sciences section and to acknowledge the great work of our new editorial board, presented on page 21. The high scientific standards maintained by *Canadian Acoustics* in its papers owe much to the continuing dedication of the journal's reviewers, who give freely of their time and expertise. It is a pleasure to pay tribute to this contribution by recognizing those who have participated in the review process in 2016, as listed on page 23.

After the success of the special issues in June 2015 and 2016 with regional content from the greater Montreal and Toronto area, it is the greater Halifax area that will be covered. Make sure to contribute, details are provide on page 43, as these issues will become nothing less than a veritable “Who's who” in acoustics among Canada's major cities.

Also mark your calendar for the upcoming Acoustics Week in Canada (AWC17) that will take place October 11-13, 2017, in Guelph (ON), as per the Call for Paper on page 37.

Avant de commencer la lecture de ce numéro, veuillez vérifier que vos coordonnées, listées dans l'annuaire des 288 abonnés, à partir de la page 62, soient bien à jour. Cette année nous avons marqué les champs manquants à l'aide d'un « ? » pour que l'information manquante soit clairement visible pour tous. N'étant pas le Père Noël, lorsque nous n'avons pas votre adresse postale, nous ne pouvons pas vous faire parvenir votre journal! Ainsi que vous le réalisez, nous sommes une association de bénévoles et nous comptons maintenant beaucoup sur nos membres pour visiter notre site web à <http://jcaa.caa-aca.ca>, certainement pour y lire leur journal sous forme électronique ou y consulter chacun des articles paru durant les 42 dernières années, mais aussi pour maintenir leurs coordonnées à jour!;-)

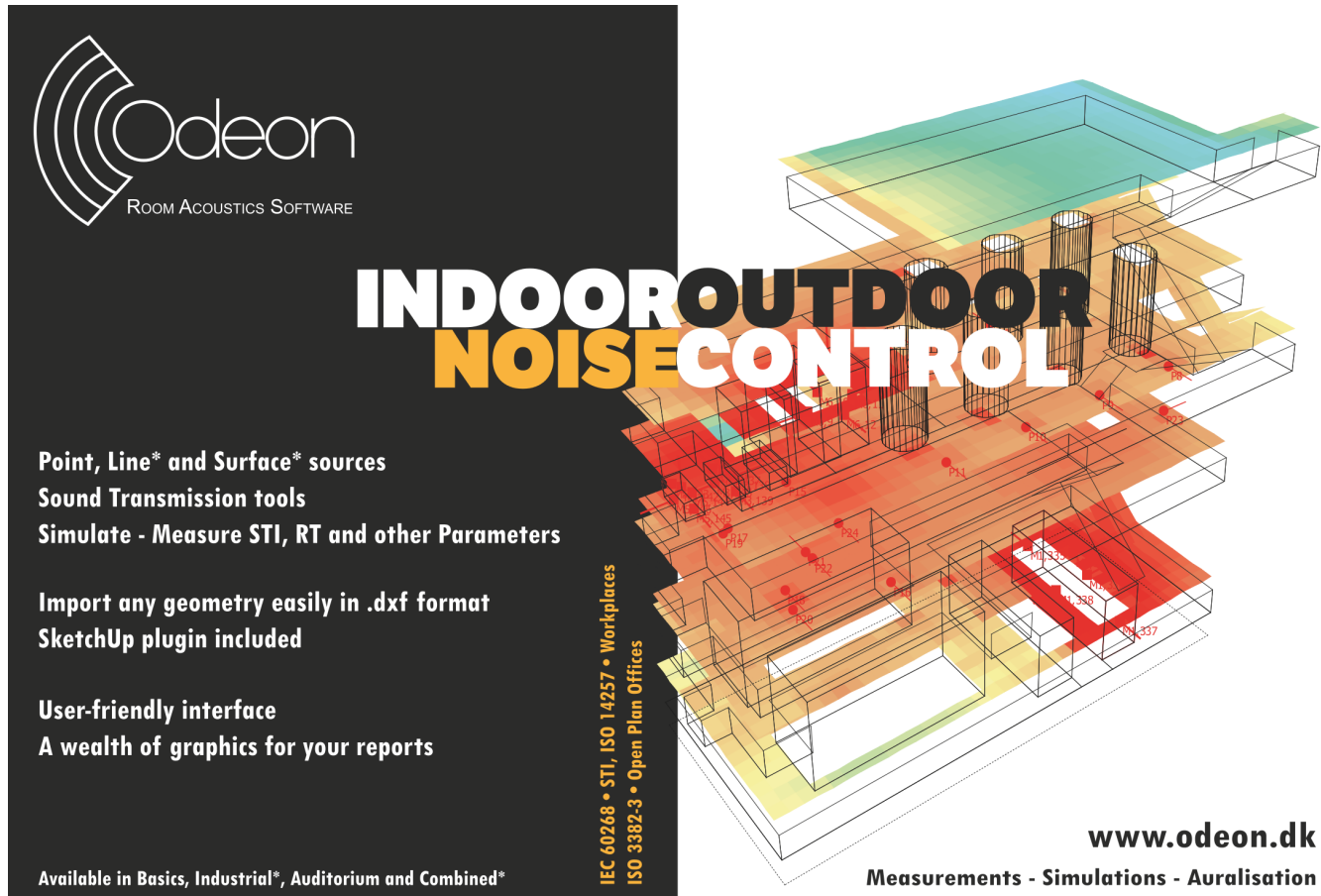
Sur cet habituel appel à l'action, je vous souhaite à tous un très joyeux temps des fêtes.

Jérémie Voix  
Rédacteur en chef

Before you start reading this issue, please make sure that your contact information is up-to-date; please check the membership directory of our 288 subscribers starting on page 62. This year, we marked the missing information with the “?” symbol to make it clear to everyone. As we don't have Santa's capabilities, we really need your postal address to send you your journal. As you know, we are a volunteer-based association and we now count on our members to visit the journal's website, at <http://jcaa.caa-aca.ca> to read their electronic journal issues (or access one of any articles published over the last 42 years), but also to maintain their contact information up-to-date! ;-)

On this usual call for action, I wish you all season's greetings and happy holidays.

Jérémie Voix  
Editor-in-Chief



**Odeon**  
ROOM ACOUSTICS SOFTWARE

**INDOOR OUTDOOR  
NOISE CONTROL**

Point, Line\* and Surface\* sources  
Sound Transmission tools  
Simulate - Measure STI, RT and other Parameters

Import any geometry easily in .dxf format  
SketchUp plugin included

User-friendly interface  
A wealth of graphics for your reports

IEC 60268 • STI, ISO 14257 • Workplaces  
ISO 3382-3 • Open Plan Offices

[www.odeon.dk](http://www.odeon.dk)  
Measurements - Simulations - Auralisation

---

## President's Message Message du Président



Special thanks to last year's conference organizing team led by Kathy Pichora-Fuller (University of Toronto) and Claire Wakefield (Wakefield Acoustics). The meeting, held in downtown Vancouver, featured two and a half days of engaging plenaries, technical papers, and exhibitor showcases, as well as an awe-inspiring performance by Sid Fels (UBC) and his talented students. Hearty congratulations to our student presentation award winners: Huiwen Goy (University of Toronto), Gabriel Nespoli (Ryerson University), and Brendan Rideout (University of Hawaii at Manoa).

After 6 years of service, Sean Pecknold of DRDC Atlantic is stepping down as our Webmaster. We owe him a great deal of gratitude. He has generously offered to stay on for just a little while longer allowing for a smooth transition to our new webmaster, Philip Tsui of Wakefield Acoustics. Philip was instrumental in making the Vancouver meeting a success and we are thrilled to have him serve the Association in this new capacity.

This year, our Acoustics Week in Canada meeting will take place in Guelph, Ontario. Peter VanDelden of RWDI will serve as the convenor and Christian Giguère will be the technical chair. The meeting will take place between the 11th and 13th of October. More information will soon be available at <http://awc.caa-aca.ca>.

At the last general meeting, we voted to maintain a slate of 12 directors in total (including the 4 officers). Kathy Pichora-Fuller did not seek re-election. All prior members of the board were acclaimed, as was our new director Andy Metalka of SVS Canada. We are in need of several new directors this coming year. If you might be interested please contact me or one of our board members.

Frank A. Russo, CAA President

Un grand merci à l'équipe organisatrice de la conférence de l'an dernier, dirigée par Kathy Pichora-Fuller (University of Toronto) et Claire Wakefield (Wakefield Acoustics). La rencontre, qui s'est tenue au centre ville de Vancouver, comportait deux journées et demi de séances plénières, d'articles techniques, de présentations d'exposants, ainsi qu'une performance impressionnante par Sid Fels (UBC) et ses étudiants talentueux. Nous présentons nos sincères félicitations aux lauréats des prix des meilleures présentations étudiantes : Huiwen Goy (University of Toronto), Gabriel Nespoli (Ryerson University) et Brendan Rideout (University of Hawaii at Manoa).

Après 6 années de service, Sean Pecknold, de RDDC Atlantique, abandonne son poste de webmaster. Nous lui devons beaucoup de reconnaissance. Il a généreusement offert de rester un peu plus longtemps pour permettre une transition en douceur à notre nouveau webmaster, Philip Tsui, de Wakefield Acoustics. Philip a joué un rôle déterminant dans la réussite de la conférence de Vancouver et nous sommes ravis de le voir continuer en tant que bénévole auprès de notre association.

Cette année, la Semaine canadienne de l'acoustique se tiendra à Guelph, Ontario. Peter VanDelden (RWDI) sera l'organisateur et Christian Giguère sera le vice-président de la conférence. La rencontre aura lieu du 11 au 13 octobre 2017. De plus amples informations sont disponibles sur <http://awc.caa-aca.ca>.

À la dernière assemblée générale, nous avons voté et décidé de maintenir un conseil de 12 administrateurs, dont 4 officiers. Kathy Pichora-Fuller n'a pas posé sa candidature pour la réélection. Tous les autres membres du conseil ont été réélus par acclamation, incluant le nouvel administrateur Andy Metalka, de SVS Canada. Nous avons besoin de plusieurs nouveaux administrateurs cette année. Si vous êtes intéressé, contactez-moi ou un de nos membres.

Frank A. Russo, Président de l'ACA

For  
Digital Recorders

# Introducing

For  
USB A/D Systems

## PHANTOM POWER



**7052PH**  
Measurement Mic System  
**7052H Type 1.5™**  
Titanium Diaphragm  
3Hz to >20 kHz  
<20 dBA > 140 dB SPL  
**MK224** (<14 dBA to >134 dB SPL) Optional  
**4048 Preamp**

Superior  
IEC 1094 Type 1  
Long-term Stability  
Temperature and Humidity  
Performance

**Now in Stock**

**Phantom  
to IEPE/ICP  
Adaptor  
Supplies 3-4 mA  
Power  
Accelerometers  
Microphones**

**ICP1248**

**A** **B**  
**C** **e**  
**O** **g**  
**u** **i**  
**S** **n**  
**t** **s**  
**i** **w**  
**c** **i**  
**S** **t**  
**O** **h**  
**A**  
**C**  
**O**



**MATT™  
Family**

**Mic  
Attenuator**

**Handle Higher Sound Pressure Levels**

**ACO Pacific, Inc., 2604 Read Ave., Belmont, CA 94002**

Tel: (650) 595-8588 FAX: (650) 591-2891 E-Mail: sales@acopacific.com

Web Site: www.acopacific.com

TM

# USING THE PARAMETERS OF DEFINITION, D<sub>50</sub>, AND REVERBERATION TIME, RT, TO INVESTIGATE THE ACOUSTIC QUALITY OF CLASSROOMS

Samuel Ansay and Paulo Henrique Trombetta Zannin\*

Laboratory of Environmental and Industrial Acoustics and Acoustic Comfort, Federal University of Paraná – UFPR, Brazil

\*Corresponding author : [paulo.zannin@gmail.com](mailto:paulo.zannin@gmail.com)

---

## Résumé

Les paramètres de définition, D<sub>50</sub>, et le temps de réverbération, RT, ont été utilisés dans cette étude pour évaluer la qualité acoustique des salles de classe qui avaient été rénovées. Les paramètres D<sub>50</sub> et RT ont été mesurés par la méthode de la réponse impulsionnelle. L'analyse de RT dans les salles de classe après leur rénovation montre que ce paramètre a augmenté. L'analyse des valeurs mesurées de D<sub>50</sub> a conduit à la conclusion que, malgré l'augmentation de la RT, de nombreux points à l'intérieur des classes affichées bonne qualité acoustique. Cette découverte suggère que les évaluations de la qualité acoustique des salles de classe devraient impliquer non seulement l'analyse de RT, mais aussi du paramètre de la définition, D<sub>50</sub>.

**Mots clés:** Le Temps de Réverbération, Définition, Salles de classe, La qualité acoustique.

## Abstract

The parameters of Definition, D<sub>50</sub>, and Reverberation Time, RT, were used in this study to evaluate the acoustic quality of classrooms which had been renovated. The parameters D<sub>50</sub> and RT were measured via the impulse response method. The analysis of RT in the classrooms after their renovation shows that this parameter increased. The analysis of the measured values of D<sub>50</sub> led to the conclusion that, notwithstanding the increase in RT, many points inside the classrooms still displayed a fair acoustic quality. This finding suggests that evaluations of the acoustic quality of classrooms should involve not only the analysis of RT but also of the parameter of Definition, D<sub>50</sub>.

**Keywords:** Reverberation time, Definition, Classrooms, Acoustic quality.

---

## 1 Introduction

This article reports on a study of the acoustic quality of two classrooms after they were renovated. The main renovation consisted of the substitution of the ceiling material, after which the faculty members teaching in these classrooms reported that they had the impression that the rooms were "noisier" and that they felt they had to talk louder. In principle, the decrease in acoustic quality was due to the substitution of the original acoustic ceiling tiles for PVC ceiling panels.

Research on acoustic quality of classrooms is described in the current literature, both in public schools and in university classrooms [1-6]. The acoustic performance of classrooms is usually analyzed based on the reverberation time [3-6]. This paper describes a study of the acoustic quality of classrooms based not only on the reverberation time, RT, but also on the parameter of Definition D<sub>50</sub>, which is described by Fasold and Veres [7].

## 2 Materials and Methods

### 2.1 Characteristics of the classrooms before their renovation

The classrooms are located in the Polytechnic Center of the Federal University of Paraná in Curitiba, Brazil. These

classrooms, which are referred to here as PG04 and PG 06, were originally built with the same dimensions as an auditorium and a volume of 295 m<sup>3</sup>. The ceiling in both classrooms was lowered and covered with acoustic ceiling tiles [5] (see Figure 1). The material shown in Fig. 1 was supplied by the manufacturer in the form of 2 cm thick 30 x 30 cm tiles. After their renovation, the acoustic lining illustrated in Figure 1 was replaced with PVC ceiling panels (Figure 2). Brazilian manufacturers supply PVC ceiling panels with 3.65 m length, 12 cm width and 1 cm thickness.

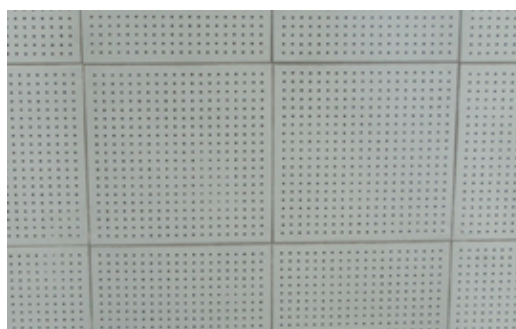


Figure 1: Acoustic ceiling tiles.



**Figure 2:** PVC ceiling panels.

Table 1 shows the sound absorption coefficient of the materials used in the ceiling of the classrooms before and after the modification. The acoustic ceiling tile absorption coefficient was taken from the book "Acoustical Designing in Architecture," by Knudsen and Harris [5]. The sound absorption coefficient of the PVC ceiling tiles was obtained from the Institute for Technological Research, of the University of São Paulo, which is the largest university in Latin America.

**Table 1:** Absorption Coefficient of the ceiling.

Absorption Coefficient	125 Hz	250 Hz	500 Hz	1000 Hz	2000 Hz	4000 Hz
Acoustic ceiling tiles [8]	0.25	0.49	0.69	0.78	0.61	0.48
PVC ceiling tiles [9]	0.01	0.01	0.02	0.02	0.02	0.02

Table 2 shows the reverberation times measured before the ceiling tiles were substituted [4]. No measurements of the parameter  $D_{50}$  were taken performed before the classrooms were renovated.

**Table 2:** RT measured in rooms PG 04 and PG 06

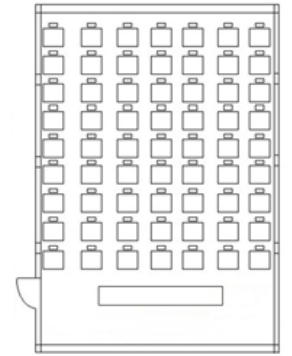
Frequency [Hz]	PG 04	PG 06
125	0.9	1.0
250	0.8	0.7
500	0.7	0.7
1,000	0.7	0.6
2,000	0.6	0.6
4,000	0.5	0.5
Average RT	0.70	0.68

## 2.2 Characteristics of the classrooms after their renovation

Room PG 04 underwent the greatest changes, with the removal of its floor, which increased its original volume of  $295 \text{ m}^3$  to  $331 \text{ m}^3$ . In addition, the original four-student desks were replaced with individual desks and chairs, as illustrated in Figures 3 and 4.



**Figure 3:** Room PG 04 today

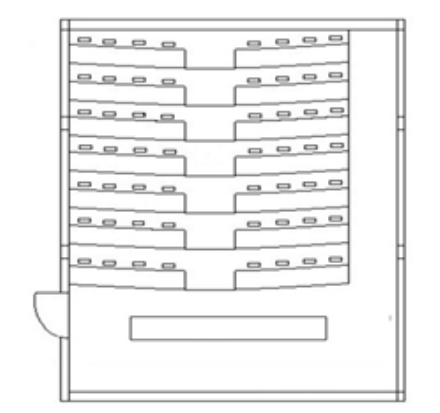


**Figure 4:** Floor plan of room PG 04.

The original auditorium design and volume of  $295 \text{ m}^3$  of room PG 06 were left unchanged, as shown in Figures 5 and 6.

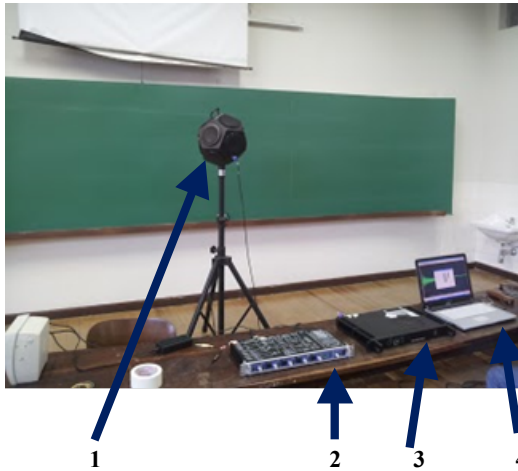


**Figure 5:** Internal view of room PG 06.



**Figure 6:** Floor plan of room PG 06.

Measurements were performed with the method of the impulse response, as recommended by the standard ISO 3382-2:2008 – Acoustics – Measurement of room acoustic parameters – Part 2: Reverberation time in ordinary rooms [10]. The measurements were taken with the following devices: a Brüel & Kjaer 4296 omnidirectional sound source, Brüel & Kjaer 2238 sound level meter, DIRAC 3.1 software and Fireface 800 audio interface. The measurements in both classrooms were taken with the sound source located at the center on the stage, in the position typically occupied by the teacher (Figure 7). The sound analyzer was positioned at the location of the students’ chairs, at a height of 1.2 m from the ground (Figure 8).



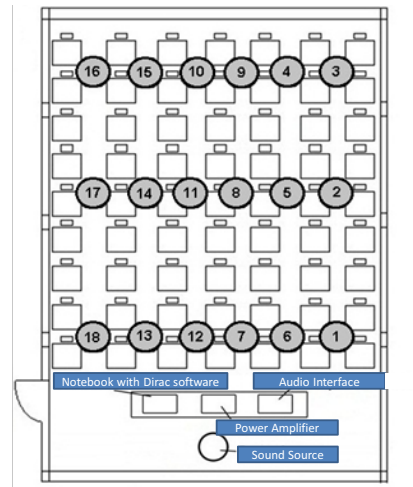
**Figure 7:** Equipment for measuring RT and D50 : 1) Omnidirectional sound source; 2) Fireface 800 audio interface; 3) Power amplifier; 4) Notebook with Dirac software.

B&K 2238 sound level meter – Room PG 06

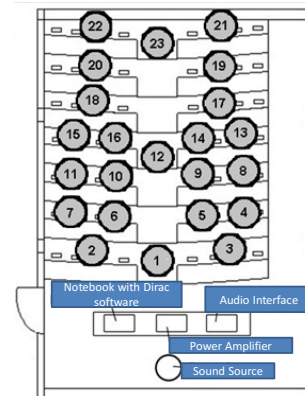


**Figure 8:** Position of the sound level meter at the students’ seats.

Figure 9 depicts the positions of the 18 points evaluated in room PG 04 while Figure 10 shows the positions of the 23 points measured in room PG 06.



**Figure 9:** Location of the measuring points in room PG 04.



**Figure 10:** Location of the measuring points in room PG 06.

As reference values for comparison, the values suggested by Marshall [11] were used for D<sub>50</sub> (Table 3), and those suggested by WHO [12-13] and by the Brazilian standard NBR 12179 [14] for RT (Table 4).

**Table 3:** D<sub>50</sub> values calculated from Figure 6 of Marshall’s paper [11].

	D <sub>50</sub> [%]
Excellent	0.86 to 1.0
Good	0.67 to 0.86
Fair	0.39 to 0.67
Poor	0.17 to 0.39
Bad	0.06 to 0.17

**Table 4:** Recommended reverberation times for classrooms

Country	Reverberation Time - RT [s]	Volume – V [m <sup>3</sup> ]
Brazil <sup>14</sup>	0.6 to 0.7	270 ≤ V ≤ 600
WHO <sup>12-13</sup>	RT = 0.6	-

### 3 Results and Discussion

Table 5 lists the RT measured in room PG 04, and Table 6 describes the values of  $D_{50}$  measured in this classroom.

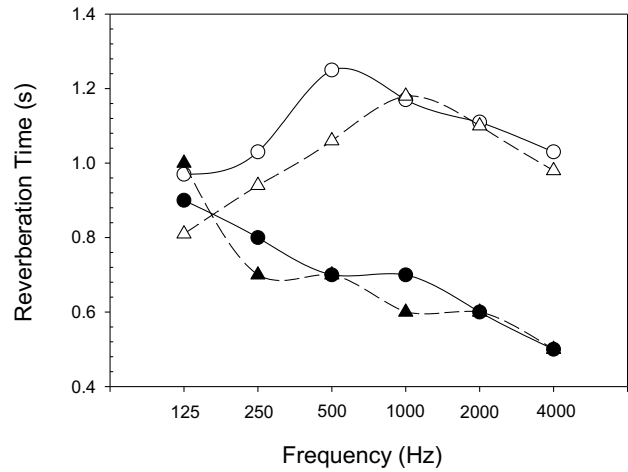
**Table 5:** Measured RT in room PG 04

Frequency [Hz]	RT [s]
125	0.97
250	1.03
500	1.25
1000	1.17
2000	1.11
4000	1.03
Average RT	1.1

**Table 6:** Measured  $D_{50}$  in room PG 04

Position of the measuring points	$D_{50}$ [%]
1	0.47
2	0.34
3	0.32
4	0.38
5	0.44
6	0.51
7	0.54
8	0.41
9	0.33
10	0.33
11	0.42
12	0.47
13	0.54
14	0.36
15	0.30
16	0.30
17	0.49
18	0.53

The figure 11 below represents the combined results of the RT measurements of classroom PG04 before and after its renovations (changes in acoustic ceiling tiles and room volume) and of classroom PG06 after the change in acoustic ceiling material.



**Figure 11:** Reverberation times (s) in PG04 (circle) and PG06 (triangle) before (black symbols) and after (white symbols) the renovations.

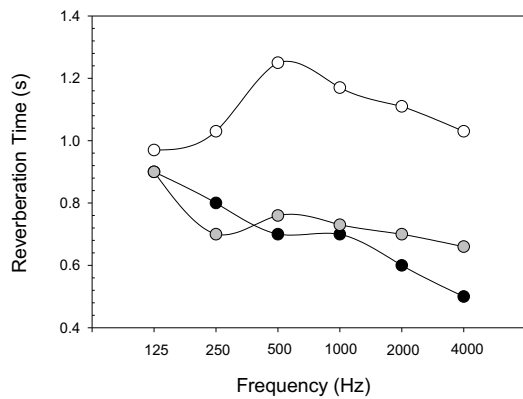
Figures 12 and 13 show the PG04 classroom fully occupied at the time of measurement of RT. Figure 14 shows the measurements of the RT, in three different situations: 1) With acoustic ceiling tiles – black circles – empty room; 2) After renovation, with PVC ceiling panels – white circles – empty room; and 3) After renovation with PVC ceiling panels, grey circles – room fully occupied. The maximum classroom capacity is of 50 students. The average RT for situation 1 is 0.70 s, for the situation 2 the average RT is 1.1 s and for the situation 3 the average RT is 0.75 s.



**Figure 12 :** Measurement of RT in room PG04



**Figure 13 :** Measurement of RT in room PG04



**Figure 14:** Reverberation time measurements in room PG04

Figure 14 shows that when the classroom is fully occupied, the average RT is equal to 0.75 s, and is slightly above the upper limit set by the Brazilian Standard [14], which states that the optimal RT should be between 0.6 and 0.7 s as can be seen in Table 4.

Table 7 describes the RT measured in room PG 06 while Table 8 lists the values of  $D_{50}$  measured in the same classroom.

**Table 7:** Measured RT in room PG 06

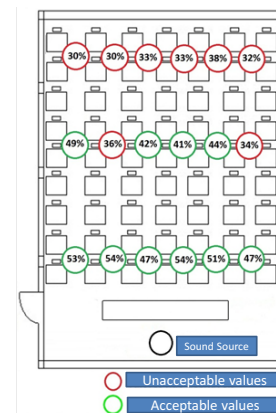
Frequency [Hz]	RT [s]
125	0.81
250	0.94
500	1.06
1000	1.18
2000	1.10
4000	0.98
Average RT	1.0

The RT was analyzed based on a comparison of the values measured before (Table 2) and after (Tables 5 and 7) the renovation. As can be seen, the RT in room PG 04 increased by 57%, passing from an average value of RT 0.70 s to 1.1 s, while in room PG 06 the RT increased by 47%, with the average value passing from 0.68 s to 1.0 s. It was found that after the renovation, the average values of RT exceeded the recommended values listed in Table 4, indicating a decline in the acoustic quality of the classrooms. In room PG 04, the measurements of  $D_{50}$  taken at the first row of desks, indicated on the floor plan in Figure 15, show values ranging from 47 to 54%. These values are considered *Fair*, according to Marshall [11] (Table 3). The six measuring points located in the middle of room PG 04 showed  $D_{50}$  values ranging from 34 to 49%, varying from *Poor* to *Fair*. The last 6 points in Figure 12 showed  $D_{50}$  values of 30 to 38%, which are considered *Poor*. Of the 18 points measured in room PG 04, the acoustic quality reached at 10 points was considered *Fair*, while at 8 points the quality was considered *Poor*. The renovation in room PG 04 involved not only the substitution

of its acoustic ceiling tiles but also a change in its volume due to the removal of its floor, which altered the room's original volume of 295 m<sup>3</sup> to 331 m<sup>3</sup> (see Figures 3 to 6)

**Table 8:** Measured  $D_{50}$  in room PG 06

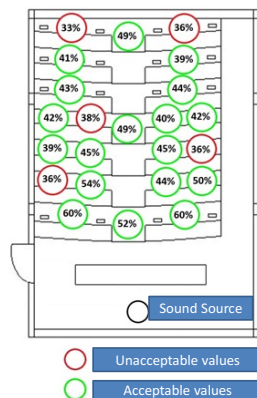
Position of the measuring points	$D_{50}$ [%]
1	0.52
2	0.60
3	0.60
4	0.50
5	0.44
6	0.54
7	0.36
8	0.36
9	0.45
10	0.45
11	0.39
12	0.49
13	0.42
14	0.40
15	0.42
16	0.38
17	0.44
18	0.43
19	0.39
20	0.41
21	0.36
22	0.33
23	0.49



**Figure 15:** Floor plan of room PG 04, showing the location of the measuring points and the values of  $D_{50}$  in percent [%]. The green color shows the points within the range of 39% to 67%, which are considered *Fair*, according to Marshall [11].

Figure 16 illustrates the values of  $D_{50}$  measured in room PG 06. As can be seen, only 5 of the 23 points measured in this classroom showed an acoustic quality rated as *Poor*

[11]. On the other hand, the vast majority of points, i.e., 18 points, achieved the qualitative evaluation of *Fair* conformed Marshall [11].



**Figure 16:** Floor plan of room PG 06, showing the location of the measuring points and the values of  $D_{50}$ , in percent [%]. The *green color* shows the points within the range of 39% to 67%, which are considered *Fair*, according to Marshall [11].

## 4 Conclusions

The present study indicated that the acoustic quality descriptor of Definition,  $D_{50}$ , is a parameter that can complement the traditional analysis of quality of classrooms based on measurements of RT. As shown by the RT measurements taken before and after the renovations, the acoustic quality of the classrooms decreased markedly, as indicated by the increase in the average RT.

This work also shows the mistake with the change in the ceiling of the classroom. It is clear that the use of PVC ceiling increased the RT in classrooms. The measurement of RT in fully occupied PG04 showed that the average RT approached the limit indicated by the Brazilian Standard [14], as can be seen in Table 4.

Also important for assessing the acoustic quality of classrooms is the measurement of STI - Speech Transmission Index [15], but for that it is necessary to have the proper equipment – a *mouth simulator*.

Finally, it should be mentioned that changing the ceiling of the classroom was an administrative decision, without having gone through the evaluation of the Acoustics Laboratory of the Federal University of Paraná.

## Acknowledgments

The authors gratefully acknowledge the German Government, through the German Academic Exchange Service - DAAD (Deutscher Akademischer Austauschdienst) and the Brazilian Government, through the National Council for Scientific and Technological Development – CNPq, for their financial support, which enabled the purchase of the sound level meters and software used in this study.

## References

- [1] Hodgson M. Experimental investigation of the acoustical characteristics of university classrooms. *J. Acoust. Soc. Am.*, 106 (1999) 1810 – 1819.
- [2] Hodgson M. Rating, ranking, and understanding acoustical quality in university classrooms. *J. Acoust. Soc. Am.*, 112 (2002) 568 – 575.
- [3] Zannin PHT & Loro CP. Measurement of the ambiente noise level, reverberation time and transmission loss for classrooms in a public school. *Noise Control Engineering Journal*, 55 (3) (2007) 327 – 333.
- [4] Zannin PHT & Ferreira AMC. Field measurements of acoustic quality in university classrooms. *J. Sci & Ind Research*, 68 (2009) 1053-1057.
- [5] Zannin PHT & Zwirter DP. Evaluation of the acoustic performance of classrooms in public schools. *App. Acoustics*, 70 (2009) 626-635.
- [6] Passero CRM & Zannin PHT. Statistical comparison of reverberation times measured by the integrated impulse response and interrupted noise methods, computationally simulated with ODEON software, and calculated by Sabine, Eyring and Arau-Puchades' formulas. *App. Acoustics*, 71 (2010) 1204–1210.
- [7] Fasold W & Veres E. *Schallschutz + Raumakustik in der Praxis* (Noise Control and Room Acoustics). Huss Medien GmbH. Verlag Bauwesen, Berlin, 2008. (in German).
- [8] Knudesen VO & Harris CM. *Acoustical Designing in Architecture*. Published for the Acoustical Society of America by the American Institute of Physics, 1988.
- [9] Personal communication - from the Institute for Technological Research, of the University of São Paulo. In Portuguese) (Comunicação pessoal do - Instituto de Pesquisas Tecnológicas da Universidade de São Paulo – USP, Brasil. Em português).
- [10] International Organization for Standardization – ISO 3382-2:2008 – Acoustics – Measurements of room acoustic parameters – Part 2: Reverberation time in ordinary rooms. Switzerland, 2008.
- [11] Marshall LG. An acoustics measurement program for evaluating auditoriums based on the early/late sound energy ratio. *Journal of the Acoustical Society of America*, 96 (1994) 2251-2261.
- [12] World Health Organization – WHO. *Noise in schools*. Geneva, 2001.
- [13] Shield BM & Dockrell JE. The effects of noise on children at school: A review. *Building Acoust.*, 10 (2) (2003) 97-106.
- [14] ABNT – Associação Brasileira de Normas Técnicas, 1992. NBR 12179: Tratamento acústico em recintos fechados: Procedimento: [Brazilian Association of Technical Standards, 1992. NBR 12179: Acoustic treatment in enclosed spaces: Procedure]. Rio de Janeiro (in Portuguese).
- [15] Bradley J.S. Speech transmission index in classrooms. *J. Acoust. Soc. Am.*, 80 (3) (1986) 846 - 854.

# A COMPARATIVE STUDY BETWEEN DIFFERENT HELMHOLTZ RESONATOR SYSTEMS

Md. Amin Mahmud<sup>\*1</sup>, Md. Shahriar Islam<sup>2</sup>, Md. Zahid Hossain<sup>3</sup>, Mir Md. Maruf Morshed<sup>4</sup>

<sup>1</sup> Dept. of Mechanical and Chemical Engineering, Islamic University of Technology (IUT), Bangladesh.

<sup>2</sup> Department of Mechanical and Chemical Engineering, IUT, Gazipur, Bangladesh.

<sup>3</sup> Department of Mechanical and Chemical Engineering, IUT, Gazipur, Bangladesh.

<sup>4</sup> Department of Mechanical Engineering, Jubail University College, K.S.A.

---

## Résumé

Cet article propose un résonateur d'Helmholtz cylindrique connecté à un conduit pour en atténuer le bruit de basse fréquence et optimisé en utilisant la méthode des éléments finis. Au départ, un système de résonateur à deux degrés de liberté identiques (2-DDL) a été ajusté en termes de position relative et de l'orientation en adaptant une publication existante sur un système de résonateur unique à 2 DDL. La meilleure position relative des deux résonateurs est étudié en les plaçant en deça des ventres et noeuds de la longueur d'onde de la source sonore et de l'orientation relative optimale entre les résonateurs se trouve également à un espacement relatif optimal. Enfin, le système optimisé à deux degrés de libertés de résonateurs identiques a été comparée à trois études publiées d'un unique résonateur à 2 DDL, d'un unique résonateur à 1-DDL et à deux systèmes résonateurs à 1-DDL, et les résultats indiquent que le systèmes à deux résonateurs identiques 2-DDL peut fournir une gamme plus large d'atténuation pour une bande passante de 300 Hz. Les résultats analytiques et numériques de perte de transmission obtenus pour l'adaptation d'un unique système à 2-DDL ont été validés avec les résultats expérimentaux publiés et une bonne concordance a été trouvée.

**Mots clefs :** bruit basses fréquences, résonateur d'Helmholtz, 1-DDL, 2-DDL, méthode des éléments finis

## Abstract

This paper proposes a best fit cylindrical Helmholtz resonator system attached to a duct for attenuating the low frequency noise using finite element method. Initially, an optimized system of two identical 2-DOF resonators in terms of relative position and orientation by adapting a published single 2-DOF resonator system. The optimum relative position of the two resonators is studied by placing them at less than antinode, antinode and node of the wavelength of sound source and the optimum relative orientation between the resonators is also found out at that optimum relative spacing. Finally, the optimized system of two identical 2-DOF resonators is compared with three published studies of single 2-DOF, single 1-DOF and two identical 1-DOF resonator systems and the results indicates that two identical 2-DOF resonator system provide a comparatively broader range of attenuation for a 300 Hz bandwidth. The obtained analytical and numerical results of transmission loss for the adapted single 2-DOF have been validated with that of the published experimental result and a good agreement is found.

**Keywords:** Low frequency noise, Helmholtz resonator, 1-DOF, 2-DOF, Finite element method

---

## 1 Introduction

Noise sources with a dominating content of low frequencies are prevalent in many occupational environments [1]. Low frequency noise (LFN) is defined a noise with a dominant frequency content of 20–200Hz'' [1] and 100 Hz 1/3 octave band as the upper end of the LF range [2]. One significant characteristic of LFN is that individuals suffering from LFN annoyance describe it as omnipresent and impossible to ignore due to the effects of vibration which are unable to locate and difficult to tune out [3]. Closing doors and windows in attempt to diminish the effects of LFN make the noise worse, due to the propagation characteristics of LFN and the low-pass filtering effect of structures. Individuals

often become irrational and anxious as attempts to control LFN fail, serving only to increase the individual's awareness of the noise [3]. The number of industrial noise sources capable of creating LFN is increasing day by day as the plant and equipment size becomes larger and automotive, aerospace industries flourishing [2].

Herman Von Helmholtz formulated a theoretical formula for calculating the resonance frequency formula developed ; a wide volume or cavity connected with a narrow orifice or neck was created in the 1850s by Hermann von Helmholtz to detect the various frequencies or musical pitches existing in music and other complex sounds [4]. Since then, it has been extensively studied in various modifications and used in compressor lines, automotive silencers and mufflers, ventilation ducts, aerospace and architectural structures to achieve a more effective solution in low frequency noise attenuation.

---

\* amahmud@alumni.ubc.ca

Current-Graduate Research Assistant, Acoustics and Noise Research Group, UBC, Vancouver, Canada.

The classical theory of a Helmholtz Resonator as an equivalent spring (cavity) and mass (neck) was developed by Rayleigh in 1945 [5]. Selamat et. el. [6] studied the effect of multidimensional propagation and showed deviations in resonance frequency from the lumped parameter analysis, particularly at low  $l/d$  ratios. To explain the non-planar sound propagation in both the neck and the cavity selamat et. el adopted multi-dimensional analytical techniques to study the noise attenuation in Helmholtz resonators with circular concentric cavity [7]. A mechanically-coupled resonators model mounted on a one-dimensional duct was developed for providing a wider bandwidth of attenuation and attenuating disturbances of varying frequency by Griffin et al. [8]. The relationship of closely spaced 1-DOF Helmholtz resonators in a 1-D plane was experimentally studied by Soh [9] which showed that when the relative spacing of two identical resonators was greater than a quarter wavelength apart, the transmission loss was greater than that of a single resonator while it declines as a result of the interaction between them when the relative spacing between the resonators is close (less than a quarter wavelength. D. Li [10] experimentally studied the effect of the resonator position on the noise attenuation and the relationship between two or more closely spaced different 1-DOF resonators near the interior wall of a chamber core cylindrical fairing on the basis of Soh [9]. Xu [11] developed the lumped-parameter theory for the piston-driven model system and examined the effect of geometry on the acoustic characteristics of side branch 2-DOF Helmholtz resonators. Farooqui, M. [12] investigated Helmholtz resonators of varying shapes and found that the noise attenuation in cylindrical resonator is better than others and the performance of noise attenuation increases significantly where the crest of the wave falls for the array of 1-DOF Helmholtz resonators located in same plane. S.Mekid and M.Farooqui [13] proposed a new design methodology for both single 1-DOF and 2-DOF Helmholtz resonators attached to pipelines to achieve optimized transmission loss. In our previous literature, Amin *et al.* [14] proposed an optimized two identical (same frequency) 1-DOF resonator system by a thorough investigation of the effect of the relative spacing and geometry of the cavity and neck on the transmission loss. Moreover, an optimized two different frequency 1-DOF resonator system in terms of relative position, orientation and geometry of both cavity and neck was studied by Amin *et al.* [15].

The objective of this study is to achieve the best fit cylindrical Helmholtz resonator system for a 300 Hz bandwidth by studying the effect of relative positions and orientations on the transmission loss of the two identical 2-DOF resonator system attached to a duct in a three-dimensional plane by a comparison with three other published resonator systems.

## 2 Method

### 2.1 Analytical Approach

#### Adaptation of a Single 2-DOF Helmholtz Resonator

The design method for a single 2-dof Helmholtz resonator has been adapted from Mekid [13]. The resonance frequency ( $f$ ) and transmission loss (TL) for a single 2- DOF Helmholtz resonator attached to a duct can be expressed by equations (1) and (2) [13] as follows

$$f_{1,2} = \frac{c}{2\sqrt{\pi}} \sqrt{\left(\frac{\alpha}{V_1} + \frac{\beta}{V_1} + \frac{\beta}{V_2}\right) \pm \sqrt{\left(\frac{\alpha}{V_1} + \frac{\beta}{V_1} + \frac{\beta}{V_2}\right)^2 - 4 \frac{\alpha}{V_1} \frac{\beta}{V_2}}} \quad (1)$$

$$Tl = 20 \log_{10} \left| \frac{\alpha}{2a_d \left( ik + \frac{\alpha}{ikV_1} \left( 1 - \frac{V_2}{V_2 + V_1 - \frac{V_2 V_1 k^2}{\beta}} \right) \right)} \right| \quad (2)$$

where, the dimensional parameter ratios  $\alpha = \frac{a_{n1}}{l_{n1}}$ ,  $\beta = \frac{a_{n2}}{l_{n2}}$ , and  $V_1 = a_{c1} \cdot l_{c1}$ ,  $V_2 = a_{c2} \cdot l_{c2}$  are the volumes of the first and the second resonator,  $a_{n1}$ ,  $a_{n2}$  are the area of cross-section of the first and the second neck and  $l_{n1}$ ,  $l_{n2}$  are their respective lengths,  $a_d$  is the cross-sectional area of the duct and  $k$  is the wave number. The transmission loss can be calculated using the equation 2 rewritten with respect to  $\alpha$  and  $\beta$  for obtaining the optimum  $\frac{\alpha}{\beta}$  or maximum transmission loss. The length of the neck is corrected by adding end correction factors considering higher wave propagation effects between the neck, cavity and duct. The end correction of a single 2-DOF Helmholtz resonator is calculated as follows [12].

$$l'_{c1} = l_{c1} + \delta_v + \delta_p \quad (3)$$

$$l'_{c2} = l_{c2} + 2\delta_v \quad (4)$$

$$\delta_v = 0.85 \left( 1 - 1.25 \frac{R_{neck}}{R_{volume}} \right) \quad (5)$$

$$\delta_p = 0.82 \frac{R_{neck}}{2} \quad (6)$$

This dimensions and parameters of the adapted single 2-DOF Helmholtz resonator [13] are illustrated in Figure 1 which is used to design the two identical 2-DOF resonators presented afterwards in this literature.

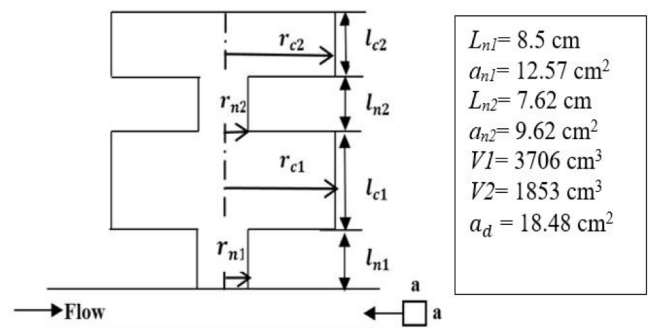


Figure 1: Single 2-DOF Helmholtz Resonator [13].

## 2.2 Numerical Approach

The transmission loss of two 2-DOF resonators is numerically computed using the ANSYS APDL FLUID module. A full acoustic harmonic analysis is performed for the resonator which calculates the pressure distribution at various frequencies at a specific frequency range. Uncoupled acoustic element FLUID221, a higher order 3-D 10-node solid element that exhibits quadratic pressure behavior is used for modeling the fluid medium. To avoid the complexity of numerical method, fluid structure interaction is neglected and considering structure absent, the entire finite element model of resonator system is considered as a fluid domain such as air. The material properties of air are:  $\rho_0$  is density of air = 1.2041 kg/m<sup>3</sup> and  $c_0$  is the speed of sound in air = 343.24 m/s. A sound source of 150 dB is considered from the noise of the jet engine at 1m distance [17] even beyond 130 dB, threshold of pain region of human being according to the Fletcher-Munson equal-loudness-level contours (1933) [18].

The main duct is considered as a square cross section of 4.3×4.3 cm like [13] and 1.5 meter long with two 2-DOF resonators designed as two cylinders which dimensions are shown in Figure 1. The mesh size is 0.11, wave/10, where the wave = 1.1m corresponding to 300 Hz, maximum working frequency considered to accommodate the whole sound wave in the duct.

PML has not been used in FE model, rather surface boundary condition is applied to the nodes of the FE model which considers the sound pressure is damped at the impedance boundary and it is used to approximate infinity. Normal velocity excitation is applied on the transparent pressure wave port (an exterior surface on which incident pressure is launched into the acoustic model and the reflected pressure wave is fully absorbed by a defined matched impedance that represents the infinity) of inlet equivalent to the sound pressure of the source. To absorb the reflected wave on the transparent port, the impedance boundary is applied to the nodes of inlet and the radiation boundary is applied to the nodes of outlet equal to  $Z_0$ , expressed by the equation 7 [16].

$$Z_0 = \rho_0 * c_0 \quad (7)$$

Normal velocity excitation can be expressed by the equation 8 [16],[18].

$$u' = -\frac{p'}{\rho_0 c_0} \quad (8)$$

where,  $u'$  is the normal velocity excitation,  $p'$  is the equivalent sound pressure in pascal  $\rho_0$  is density of air and  $c_0$  is the speed of sound in air.

The generated acoustic resonator model is shown in Figure 2. Then the solution was performed using sparse solver with tolerance 1e-008, selecting the analysis type as harmonic and the frequency range from 0 to 300 Hz. From the obtained results, the sound pressure of the outlet was taken at the proximal node of the outlet and converted to output sound pressure using equation 9 [18].

$$\text{Output Sound Pressure Level} = 20 \log_{10}(\text{sound pressure at output/reference pressure level}) \quad (9)$$

which is used to measure the transmission loss ( $TL$ ) from the sound pressure drop at the outlet from the inlet.

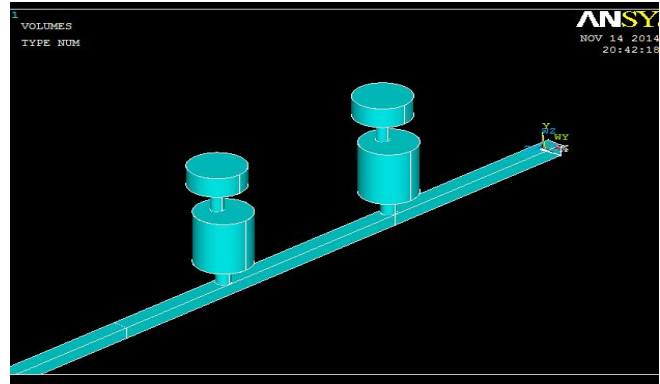


Figure 2: Numerical model of two identical 2-DOF resonators along with the duct.

### 2.2.1 Relative Positions of Two Identical 2-DOF Resonators

The effects of the relative positions of the two identical 2-DOF Helmholtz resonators on the noise attenuation are investigated to obtain the optimum relative position. For convenience, the relative positions between the two resonators are denoted as  $Z$ , where  $Z$  is the centre distance between the resonators, closely spaced; ( $< \frac{\lambda}{4}$ ), antinode; ( $\frac{\lambda}{4}$ ) and node; ( $\frac{\lambda}{2}$ ) where  $\lambda = 1.1$  metre, wavelength corresponding to 300 Hz. maximum working frequency of, as shown in Figure 3 which are described as close, antinode and node respectively later in this paper. Both the 2-DOF resonators was modelled identically, using same dimensions of geometry of the cavity and neck as mentioned in Figure. 1 for a single 2-DOF resonator [13]. The relative positions of two 2-DOF resonators were optimized in this investigation and is considered for all further investigations of this paper.

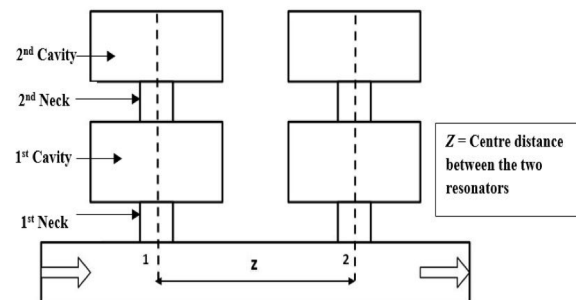


Figure 3: Relative spacing of two identical 2-DOF resonators.

### 2.2.2 Relative Orientation of Two Identical 2-DOF Resonators

The effects of the relative orientation of two identical 2-DOF resonators on the noise attenuation are investigated to obtain the optimum relative orientation at the obtained optimum relative position from the section 2.2.1. Initially there is no relative orientation between the two resonators. Afterwards, the 2<sup>nd</sup> resonator was rotated 90 and 180 degrees respectively about the 1<sup>st</sup> resonator as illustrated in Figure 4.

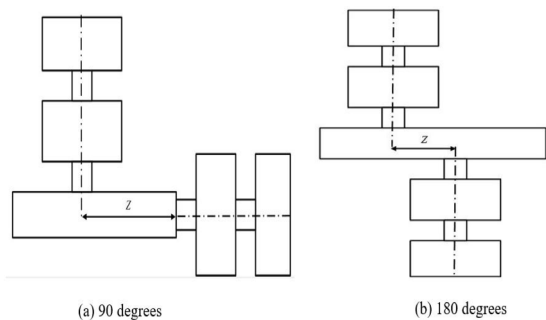


Figure 4: Relative orientation of two 2-DOF resonators.

### 3 Results

#### 3.1 Relative Positions of Two Identical 2-DOF Resonators

As can be seen in Table 1 and Figure 5 that the obtained 1<sup>st</sup> and 2<sup>nd</sup> resonance frequencies,  $f_1$  and  $f_2$  of two identical 2-DOF resonators are identical, 73 Hz and 166 Hz respectively for all 3 relative positions. The numerical results of maximum  $TL$  are 83.61 dB, 86.22 dB and 92.24 dB at  $f_1$ , 73 Hz relative to that of 63.15 dB, 69.12 dB and 73.80 dB at  $f_2$ , 166 Hz for close, antinode and node position respectively for a 150 dB sound source which indicates that the  $TL$  is relatively high at and around the both resonance frequencies. Moreover, it is very interesting to observe that at both resonance frequencies, there is nearly a 6 dB and 10 dB increase in  $TL$  at node position from the antinode and close position respectively. However,  $TL$  drops to zero i.e. sound pressure level increases at 59 Hz and 151 Hz for close; 55 Hz and 151 Hz for antinode; 45 Hz, 151 Hz and 227 Hz for node position due to anti resonance effects before rising sharply at around the 73 and 166 Hz. These results exhibit that the resonators at node position provide a wider bandwidth of noise attenuation compared to that of antinode and close position respectively.

Therefore, it can be summarized from the results that the transmission loss of two identical 2-DOF resonators can significantly vary with change of their relative positions. The optimum relative position for two identical 2-DOF resonators achieved from this analysis is node distance apart corresponding to the wavelength of 300 Hz, maximum working frequency.

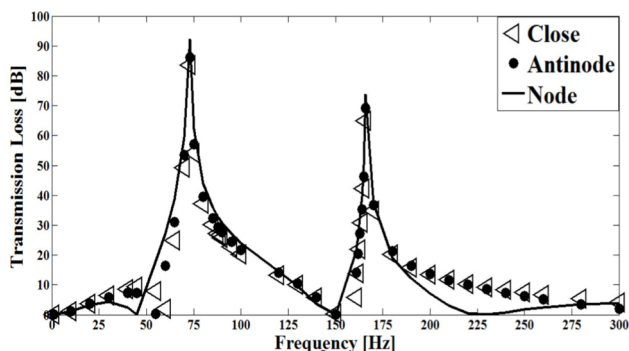


Figure 5: A comparison of numerical transmission loss for various relative positions of two identical 2-DOF resonators.

Table 1: Numerical transmission loss at two resonance frequencies for various relative positions of two identical 2-DOF resonators.

Relative Positions	Transmission Loss ( $TL$ ), dB	
	1 <sup>st</sup> Resonance Frequency ( $f_1$ ), 73 Hz	2 <sup>nd</sup> Resonance Frequency ( $f_2$ ), 166 Hz
Close	83.61	63.15
Antinode	86.22	69.12
Node	92.24	73.80

#### 3.2 Relative Orientation of Two 2-DOF Resonators

As depicted in Figure. 6 and Table 1, the numerical results of maximum  $TL$  are 92.24 dB, 91.63 dB and 87.33 dB at  $f_1$ , 73 Hz compared to that of 73.15 dB, 72.16 dB and 65.65 dB at  $f_2$ , 166 Hz for inline, 90 degree and 180 degrees respectively for a 150 dB sound source. At the first resonance frequency, there is nearly a 1 dB and 4 dB decrease in  $TL$  for inline orientation from the 90 and 180 degree relative orientation respectively while it drops nearly by 2 dB and 6 dB at the second resonance frequency. These results indicates that although the variation of  $TL$  is insignificant at 90 degree from inline orientation, it varies quite significantly in 180 degree relative orientation due to the opposing effects of the resonators.

The results clearly shows that the change of relative orientation has a significant effect on the transmission loss of two identical 2-DOF resonators particularly at the opposite direction, 180 degree relative orientation. The optimum relative orientation for two identical 2-DOF resonators achieved from this analysis is inline, no relative orientation.

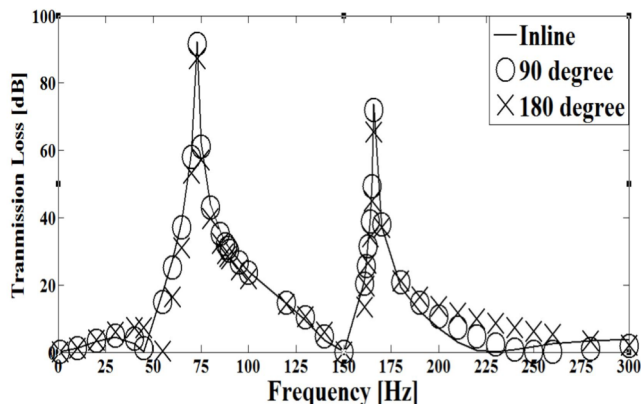


Figure 6: A comparison of numerical transmission loss for various relative orientations of two identical 2-DOF resonators.

Table 2: Numerical transmission loss at two resonance frequencies for various relative orientations of two identical 2-DOF resonators.

Relative Orientations	Transmission Loss ( $TL$ ), dB	
	1 <sup>st</sup> Resonance Frequency ( $f_1$ ), 73 Hz	2 <sup>nd</sup> Resonance Frequency ( $f_2$ ), 166 Hz
Inline	92.24	73.80
90 degree	91.63	72.16
180 degree	87.33	65.65

### 3.3 Comparison of Various Resonator Systems

The numerical transmission loss and resonance frequencies of the optimum two identical 2-DOF resonator system (Resonator A) i.e. node position and inline orientation found from sections 3.1 and 3.2 are compared with that of a single 2-DOF [13] (Resonator B), single 1-DOF [07] (Resonator C), and optimum two identical 1-DOF resonator system [14] (Resonator D) as shown in Figure 7. Moreover, the octave band numerical transmission loss of all 4 resonator systems at their respective resonance frequencies within 300 Hz are presented in Table 4 respectively. It should be mentioned that the geometry of the duct, and all the above resonator systems, cavity and neck are quite similar considering a 150 dB sound source for all cases. This findings from the above comparison can be summarized as follows-

**Table 3:** A comparison of octave band numerical *TL* of two identical 2-DOF resonators with published resonator systems.

Resonator No	Transmission Loss ( <i>TL</i> ), dB at Octave Band (Hz)				
	16	31.5	63	125	250
<b>A</b>	2.46	4.35	33.65	12.11	1.73
<b>B</b>	0.89	3.43	16.95	4.26	2.28
<b>C</b>	1.75	3.57	15.06	24.53	1.71
<b>D</b>	2.66	4.51	11.91	11.50	3.95

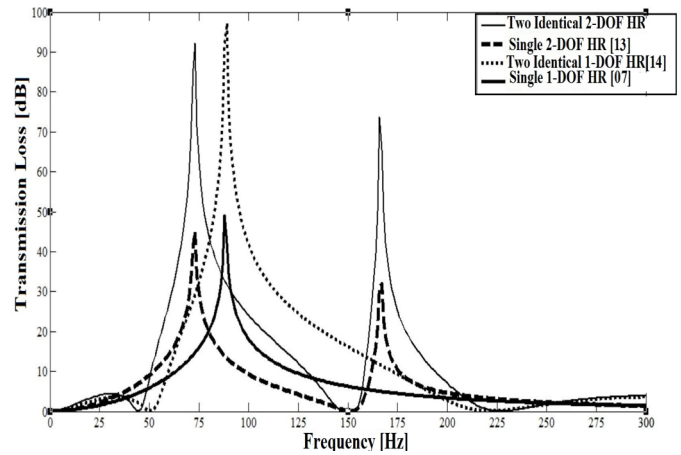
The resonance frequency of both 1-DOF resonator systems make a significant drift to 89 Hz from the 1<sup>st</sup> resonance frequency of both the 2-DOF resonator systems, 73 Hz. However, the first and second resonance frequencies of both the single and two 2-DOF system remains same like the single and two 1-DOF resonators as shown in Figure 7.

The numerical result of *TL* both two identical 2-DOF and 1-DOF resonator system at their resonance frequencies are approximately double in contrast with a single 2-DOF and two identical 1-DOF resonator system respectively as shown in Table 3.

The numerical *TL* of both the 1-DOF resonator systems is nearly 5 dB higher than that of both the identical 2-DOF resonators at their respective resonance frequencies shown in Table 3.

Octave band numerical *TL* presented in Table 4 shows that the difference of *TL* for all four resonator systems are quite negligible in frequency bands, 16, 32.5 Hz and 250 Hz. However at 63 Hz, *TL* of two identical 2-DOF resonator is around 17 dB higher than a single 2-DOF resonator; 18 dB higher than two identical 1-DOF resonators and 22 dB higher than a single 1-DOF resonator system. Hence, it can be concluded that among the 4 resonator systems, the noise attenuation performance of two identical 2-DOF resonator system is best at 63 Hz.

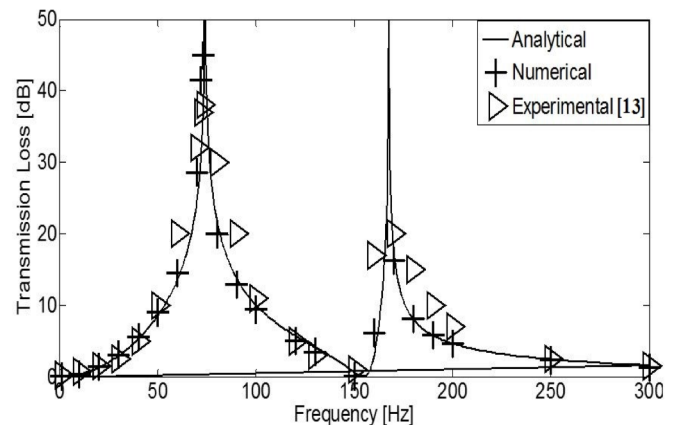
But at 125 Hz, numerical *TL* of two identical 1-DOF resonator is around 12 dB higher than two identical 2-DOF resonators; 20 dB higher than a single 2-DOF resonator and 13 dB higher than a single 1-DOF resonator system. Hence, among the 4 resonator systems, the noise attenuation performance of two identical 1-DOF resonator system is best at 125 Hz.



**Figure 7 :** A comparison of numerical transmission loss of two identical 2-DOF resonators with three published resonator systems.

### 4 Validation

A single 2-DOF Helmholtz resonator used by Mekid et al. [13] is used to validate the analytical design method described in section 2.1 using MATLAB. The same resonator is used in the ANSYS simulation described in section 2.2 to validate the level of transmission loss obtained analytically which is also validated with the published experimental results [13]. The analytical and numerical results of transmission loss matches well with the experimental results as shown in Figure 8.



**Figure 8:** A comparison of transmission loss with published experimental results for a single 2-DOF resonator [13].

### 5 Conclusion

This work demonstrates that the relative positions and orientations have a significant effect on the low frequency noise attenuation performance of two identical 2-DOF cylindrical Helmholtz resonator system. An optimum system has been achieved for the above system in terms of relative positions and orientations: relative position: node of wavelength corresponding to the maximum working frequency, relative orientation: inline, no rotation. Moreover, the comparison between the numerical transmission losses of

the 4 resonator systems shows that the noise attenuation performance of two identical 2-DOF and 1-DOF resonator systems are comparatively much better than that of both single 1-DOF and 2-DOF resonator system respectively. However, two identical 2-DOF resonator is recommended as the best fit resonator system at the low frequency range within 300 Hz since it provides a wider bandwidth of attenuation and shows better performance at most low frequencies within 300 Hz although the choice of resonator can vary depending on the target frequency of the noise source. However, it could be difficult to place the resonators at node distance apart if the length of the duct is less than the wavelength corresponding to the sound source, at particularly higher frequencies.

Future work could be further optimization of the proposed two 2-DOF resonator system by changing the geometry of the cavity and neck of the resonator similar to our published studies of two identical [14] and different frequency 1-DOF resonators [15].

Moreover, it could be of future interest to validate this work experimentally to determine the level of the transmission loss can be achieved in practice since several important factors like background noise levels, coupling effects of fluid and structure, damping effect of the material of the duct, viscous losses due to friction of the oscillation air at the neck, attenuation due to transmission and frictions in structures, increase of sound pressure level due to reflection at the duct opening are ignored in this study to avoid difficulties in the numerical simulation which may have some effect in achieving the desired result.

## References

- [1] K. Persson Waye, On the Effects of Environmental Low Frequency Noise, *Doctoral Thesis*, Department of Environmental Medicine, University of Gothenburg, ISBN 91-628-1516-4, 1995.
- [2] Rushforth, I., Moorhouse, A. and Styles, P. "A case study of low frequency noise assessed using DIN 45680 criteria". *noise notes*, 3(1): 3-18, 2000.
- [3] DeGagne, D. C., & Faszer, A. C. "Controlling Low Frequency Noise Using a Passive Silencer".
- [4] Helmholtz, H. von. "Theorie der Luftschwingungen in Röhren mit offenen Enden." *Journal für die reine und angewandte Mathematik*, 57: 1-72, 1860.
- [5] J. W. S. Rayleigh, "The Theory of sound", 2 : 293, Dover, New York, 1945.
- [6] A. Selamet, N. S. Dicky, J. M. Novak, "Theoretical, computational and experimental investigation of Helmholtz resonators with fixed volume: lumped versus distributed analyses". *Journal of sound and vibration*, 187(2) : 358-367, 1995.
- [7] A. Selamet, P. M. Radavich, N. S. Dickey, J. M. Novak, "Circular concentric Helmholtz resonators". *The Journal of the Acoustical Society of America*, 101 (1) : 41-51, 1997.
- [8] S. Griffin, S. A. Lane, S. Huybrechts, "Coupled Helmholtz resonators for acoustic attenuation". *Journal of vibration and acoustics*, 123(1) : 11-17, 2001.
- [9] Y. P. Soh, E. W. T. Yap, B. H. L. Gan, "Industrial Resonator Muffler Design". *Level 4 Thesis, University of Adelaide*, Australia, 2001.

- [10] D. Li, "Vibroacoustic behavior and noise control studies of advanced composite structures". *PhD Thesis, University of Pittsburgh*, USA, 2003.
- [11] M.B. Xu, A. Selamet and H. Kim, "Dual Helmholtz resonator". *Applied Acoustics*, 71: 822-829, 2010.
- [12] M. Farooqui, "Noise reduction in centrifugal compressors using Helmholtz resonators". *Masters-thesis*, King Fahad University of Petroleum and Minerals, Saudi Arabia, 2012.
- [13] S. Mekid, M. Farooqui, "Design of Helmholtz resonators in one and two degrees of freedom for noise attenuation in pipelines". *Acoustics Australia*, 40(3), 2012.
- [14] M. A. Mahmood, M. S. Islam, M. Z. Hossain, M. M. M. Morshed, "Noise Attenuation by Two One Degree of Freedom Helmholtz Resonators". *Proceedings in 10th Global Engineering, Science and Technology*, 202, 2015.
- [15] Md. Amin Mahmud, Md. Shahriar Islam, Md. Zahid Hossain, Mir Md. Maruf Morshed "Improvement of Noise Attenuation in a Duct Using Two Helmholtz Resonators". *International Review of Mechanical Engineering (IREME)*, 9(1): 231-236, 2015.
- [16] ANSYS Mechanical APDL Acoustic Analysis Guide, Release 15.0, *ANSYS Inc*, 2013.
- [17] Winer, Ethan. "1". *The Audio Expert*. New York and London: Focal Press. ISBN 978-0-240-82100-9, 2013.
- [18] Suzuki, Yoiti, and Hisashi Takeshima. "Equal-loudness-level contours for pure tones." *The Journal of the Acoustical Society of America* 116(2): 918-933, 2004.
- [19] Rienstra, Sjoerd W., and Avraham Hirschberg. "An introduction to acoustics." *Eindhoven University of Technology* 18:19, 2013.





ACOUSTICS



NOISE



VIBRATION

- > Noise & Vibration Control in Land-use Planning
- > Noise & Vibration Studies: Residential and Commercial
- > Building Acoustics, Noise & Vibration Control
- > Land-use Compatibility Assessments
- > Third-party Review of Peer Reports
- > Expert Witness Testimony

905-826-4546  
[answers@hgcengineering.com](mailto:answers@hgcengineering.com)  
[www.hgcengineering.com](http://www.hgcengineering.com)

# INTRINSIC AND EXTRINSIC PORTIONS OF SOFT PALATE MUSCLES IN VELOPHARYNGEAL AND OROPHARYNGEAL CONSTRICTION: A 3D MODELING STUDY

Peter Anderson<sup>1</sup>, Sidney Fels<sup>1</sup>, Ian Stavness<sup>2</sup> and Bryan Gick<sup>3,4</sup>

<sup>1</sup> Dept. of Electrical and Computer Eng., University of British Columbia, 2356 Main Mall, Vancouver, BC, Canada, V6T1Z4

<sup>2</sup> Dept. of Computer Science, University of Saskatchewan, Saskatoon, SK, Canada

<sup>3</sup> Dept. of Linguistics, University of British Columbia, 2613 West Mall, Vancouver, BC, Canada, V6T1Z4

<sup>4</sup> Haskins Laboratories, 300 George St., New Haven, CT, USA 06511

## 1. INTRODUCTION

The soft palate is essential in speech, yet understanding of soft palate muscle function remains quite coarse. Traditional descriptions of the soft palate highlight the 2D midsagittal actions of the palate with a focus on two muscles in particular: levator veli palatini (LVP), described as constricting the velopharyngeal port (VPP) by raising the soft palate, and palatoglossus (PG), described as constricting the oropharyngeal isthmus (OPI) by lowering the soft palate (Fritzell, 1969). The present paper argues that these descriptions are founded on the line-of-action of the extrinsic portions of those muscles, neglecting the role of the intrinsic portions. We present a 3D biomechanical model of the soft palate with the goal of clarifying the distinct roles that the intrinsic and extrinsic portions of these muscles play in VPP and OPI control.

Both LVP and PG comprise intrinsic and extrinsic portions relative to the soft palate (Cho et al., 2013; Kuehn & Azzam, 1978). While the extrinsic portions of LVP and PG are relatively thick and accessible, making them easy to monitor with EMG, the intrinsic portions are thin, fanned-out, and interdigitated with other muscles, making accurate EMG measurements of the intrinsic portions of these muscles prohibitively challenging (Kuehn et al., 1982). While previous studies have thus focused almost exclusively on the extrinsic portions of these muscles, the limited observations available in the literature suggest that the intrinsic portions are essential in soft palate function. E.g., Gick et al. (2014) show that the intrinsic portion of PG is important in modeling OPI closure, while Serrurier & Badin (2008) provide 3D image data revealing intrinsic reshaping of the soft palate, forming a large hump in the central posterior region of the superior palate surface as part of the closure mechanism. Further, the suggestion that the extrinsic and intrinsic portions of speech muscles may serve distinct functions finds analogy in previous studies of tongue muscles (e.g. Honda et al., 2013).

## 2. METHODS

Our upper airway (UA) model, defined and simulated using the Artistry biomechanical simulation toolkit (Lloyd, Stavness, & Fels, 2012) and composed of finite element (FE) components, rigid bodies, and skin meshes, generally follows the descriptions given in Anderson et al. (2015); however, changes were made to the soft palate

warranting further description here (illustrated in Figure 1). Based on stiffness values from Birch & Srodon (2009), the soft palate was modeled using a linear elastic material with  $E = 500$  Pa and point-to-point muscles (modeled after Peck et al. 2000) were given a passive force to approximate the muscle contribution to the overall soft palate stiffness. Muscle paths were informed by anatomical descriptions of the soft palate (Drake et al., 2010; Cho et al., 2013; Kuehn & Kahane, 1990). Reported cross-sectional areas of the LVP (Perry et al. 2013) and PG (Cho et al., 2013) were used to define the maximum muscle force following Peck et al. (2000), giving values of 10.8N for LVP, 2.1N for PGa, and 1.1N for PGp; other muscles, which do not play an active role in these simulations, were assigned a value of 3 N. Simulating Kuehn & Moon's (1998) protocol as a means of validation, a skin mesh representing the inner surface of the nasal airway was added to monitor cross-sectional area (CSA) and VPP closure; the location in the model of minimal CSA and maximal closure force was identified, and is the location reported in the remainder of this study.

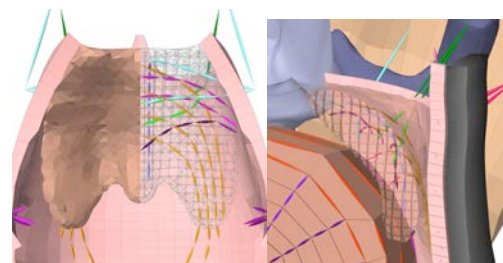
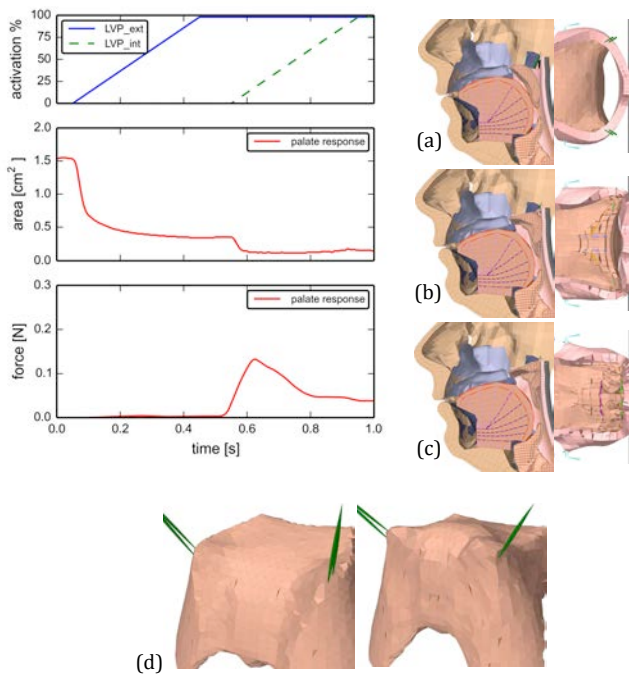


Figure 1. Front (left image) and oblique (right image) views of the soft palate model, showing: LVP (green), anterior PG (magenta), posterior PG (dark magenta), tensor veli palatini (cyan), palatopharyngeus (orange), musculus uvulae (purple).

## 3. RESULTS

Figure 2 shows results of sequentially activating the extrinsic and intrinsic portions of LVP. The CSA response (left, middle plot) shows that extrinsic LVP alone achieves 2/3 of VPP closure, yet only after the intrinsic portion of LVP is activated does the VPP completely close and the palate produce a substantial closure force (left, bottom plot) on the rear pharyngeal wall. Activating extrinsic LVP alone appears to create near-closure midsagittally, but droops along the line of the LVP (Fig. 2b). Only after the intrinsic portion of LVP activates does the soft palate strongly push back into the rear pharyngeal wall. As Figure 2d shows, activating LVP produces the characteristic "hump".



**Figure 2. Left: sequential activation of extrinsic and intrinsic LVP. Right: soft palate model responses at (a)  $t = 0.0$ s; (b)  $t = 0.5$  s (extrinsic LVP only); (c)  $t = 1.0$  s (extrinsic + intrinsic). Bottom (d): oblique posterior view of soft palate showing hump (right image) formed by LVP (50% activation).**

After LVP was activated as above and allowed to reach steady state for VPP closure, PG activation was added. We considered activation of PG as a whole, activation of only posterior PG (PGP), and activation of only the intrinsic portion or extrinsic portion of PGP. Results show that activating PG as a whole increases CSA of VPP closure and diminishes VPP closure force; however, activating only intrinsic PGP leads to no appreciable loss of VPP closure area or force. Examining the OPI, we observe that intrinsic PGP causes the largest forward motion of the uvula, producing the greatest OPI closure without compromising VPP closure. In contrast, activating any combination involving extrinsic PGP results in less forward motion of the uvula and greater compromises to VPP closure.

#### 4. DISCUSSION AND CONCLUSIONS

The intrinsic portions of LVP and PG play important roles in speech. The action of intrinsic LVP, through mediolateral compression of its fan-like shape, produces the expected hump observed in the posterior palate during VPP closure and is responsible for most of the closure force; intrinsic PG constricts the OPI without compromising VPP closure. The significant roles of the intrinsic portions of these muscles indicate serious shortcomings in the “trapdoor” representation of the soft palate, and suggest that intrinsic LVP should be carefully considered in VPP biomechanics and cleft palate repair surgery. The present simulations show that the intrinsic muscles of the soft palate

are needed for the soft palate to achieve the versatility that it is observed – and required – to have for speech production.

#### REFERENCES

Anderson, P., Harandi, N. M., Moisiuk, S., Stavness, I. and Fels, S. (2015). A comprehensive 3d biomechanically-driven vocal tract model including inverse dynamics for speech research. *Interspeech 2015*. Dresden, Germany.

Birch, M. J. and Srodon, P. D. (2009). Biomechanical properties of the human soft palate. *Cleft Pal.-Craniofac. J.*, 46, 268-274.

Cho, J. H., Kim, J. K., Lee, H.-Y. and Yoon, J.-H. (2013). Surgical anatomy of human soft palate. *Laryngoscope*, 123, 2900-2904.

Drake, R., Vogl, A. W. and Mitchell, A. W. M. (2010). *Gray's anatomy for students* (2nd ed.). Churchill Livingstone Elsevier.

Fritzell, B. (1969). The velopharyngeal muscles in speech. an electromyographic and cineradiographic study. *Acta Oto-Laryngologica*, 67, sup250.

Gick, B., Anderson, P., Chen, H., Chiu, C., Kwon, H. B., Stavness, I.,...Fels, S. (2014). Speech function of the oropharyngeal isthmus: a modelling study. *Comp. Meth. in Biomech. and Biomed. Eng.: Imaging & Visualization*, 2, 217-222.

Honda, K., Murano, E. Z., Takano, S., Masaki, S. and Dang, J. (2013). Anatomical considerations on the extrinsic tongue muscles for articulatory modeling. *Proc. Meet. Acoust.*, 19(1).

Kuehn, D. and Azzam, N. (1978). Anatomical characteristics of palatoglossus and anterior faucial pillar. *Cl. Pal. J.*, 15, 349-359.

Kuehn, D., Folkins, J., Cutting, C. (1982). Relationships between muscle-activity and velar position. *Cl. Pal. J.*, 19, 25-35.

Kuehn, D. and Kahane, J. (1990). Histologic-study of the normal human adult soft palate. *Cl. Pal. J.*, 27, 26-35.

Kuehn, D. and Moon, J. (1998). Velopharyngeal closure force and levator veli palatini activation levels in varying phonetic contexts. *J. Speech, Lang. and Hearing Res.*, 41, 51-62.

Lloyd, J. E., Stavness, I. and Fels, S. (2012). Artisynt: A fast interactive biomechanical modeling toolkit combining multibody and finite element simulation. In *Soft tissue biomechanical modeling for computer assisted surgery* (p. 355-394). Springer.

Peck, C., Langenbach, G. and Hannam, A. (2000). Dynamic simulation of muscle and articular properties during human wide jaw opening. *Arch. of Oral Biol.*, 45, 963-982.

Perry, J. L., Kuehn, D. P. and Sutton, B. P. (2013). Morphology of the levator veli palatini muscle using magnetic resonance imaging. *Cleft Pal.-Craniofac. J.*, 50, 64-75.

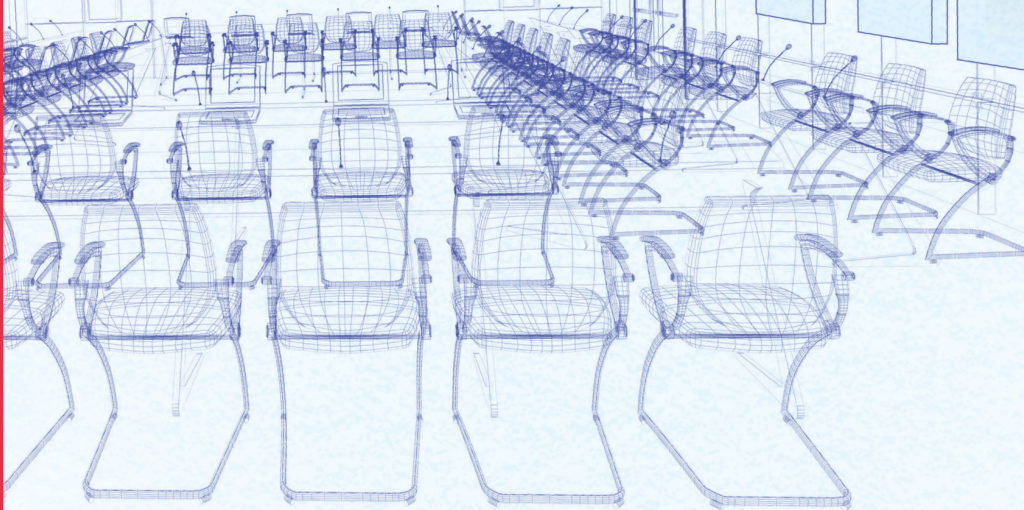
Serrurier, A. and Badin, P. (2008). A three-dimensional articulatory model of the velum and nasopharyngeal wall based on MRI and CT data. *J. Acoust. Soc. Am.*, 123, 2335-2355.

#### ACKNOWLEDGEMENTS

This research is funded by an NSERC Discovery Grant, an NSERC Strategic Grant and by CIHR grant CPG-121024.

WE CAN MAKE WHATEVER YOU MAKE

# BETTER. SAFER. QUIETER.



**Custom insulation solutions for acoustical panels start here.**

Made from basalt rock, ROXUL® Core Solutions (OEM) insulation provides excellent acoustical dampening and fire resistant properties. So whether you're designing acoustical panels, a music studio or modular office – our team of experts will work with you before, during and after fabrication to create the custom sound solution you're looking for.

Visit us at [roxul.com/oem](http://roxul.com/oem)

CONROCK® Series.  
For the better way to build.

**ROXUL**®  
The Better Insulation™

## EDITORIAL BOARD - COMITÉ ÉDITORIAL

### Hearing Conservation - Préservation de l'ouïe

Alberto Behar (416) 265-1816 albehar31@gmail.com  
Ryerson University

### Technical Notes - Exposés techniques

Umberto Berardi 416 979 5000 (3263) uberardi@ryerson.ca  
Ryerson University

### Special Issue: Canadian Acoustics Cities - Édition spéciale : Acoustique canadienne des villes

Umberto Berardi 416 979 5000 (3263) uberardi@ryerson.ca  
Ryerson University

### Musical Acoustics / Electroacoustics - Acoustique musicale / Électroacoustique

Annabel J Cohen acohen@upei.ca  
University of P.E.I.

### Signal Processing / Numerical Methods - Traitement des signaux / Méthodes numériques

Tiago H. Falk (514) 228-7022 falk@emt.inrs.ca  
Institut national de la recherche scientifique (INRS-EMT)

### Aeroacoustics - Aéroacoustique

Anant Grewal (613) 991-5465 anant.grewal@nrc-cnrc.gc.ca  
National Research Council

### Physiological Acoustics - Physio-acoustique

Robert Harrison (416) 813-6535 rvh@sickkids.ca  
Hospital for Sick Children, Toronto

### Underwater Acoustics - Acoustique sous-marine

Garry J. Heard 902-426-3100 x310 garry.heard@gmail.com  
Defence R-D Canada Atlantic Research Centre

### Psychological Acoustics - Psycho-acoustique

Jeffery A. Jones jjones@wlu.ca  
Wilfrid Laurier University

### Consulting - Consultation

Tim Kelsall 905-403-3932 tkelsall@hatch.ca  
Hatch

### Speech Sciences - Sciences de la parole

Michael Kieft mkieft@dal.ca

### Architectural Acoustics - Acoustique architecturale

Jean-François Latour (514) 393-8000 jean-francois.latour@snclavalin.com  
SNC-Lavalin

### Shocks / Vibrations - Chocs / Vibrations

Pierre Marcotte marcotte.pierre@irsst.qc.ca  
IRSST

### Hearing Sciences - Sciences de l'audition

Kathleen Pichora Fuller (647) 794-7560 k.pichora.fuller@utoronto.ca  
University of Toronto

### Physical Acoustics / Ultrasounds - Acoustique physique / Ultrasons

Werner Richarz wricharz@echologics.com

### Engineering Acoustics / Noise Control - Génie acoustique / Contrôle du bruit

Joana Rocha joana.rocha@carleton.ca  
Carleton University

### Bio-Acoustics - Bio-acoustique

Jahan Tavakkoli (416) 979-5000 jtavakkoli@ryerson.ca  
Ryerson University



**UNI Web**  
 The network of research organizations  
 Le réseau des organismes de recherche

An information system with academic CV management, expertise inventory and networking capabilities for research institutions and associations.

Un système d'information avec gestion de CV académique, un inventaire de l'expertise interne et des capacités de réseautage pour des organismes de recherche.

With UNIWeb, researchers can:

**Streamline**

funding applications with Canadian Common CV integration

**Reuse**

CCV data to generate academic CVs and progress reports

**Mobilize**

knowledge by creating engaging webpages for research projects

Avec Uniweb, les chercheurs peuvent:

**Simplifier**

les demandes de financement grâce à l'intégration au CV commun canadien

**Réutiliser**

les données du CVC pour générer des CV académiques et des rapports de progrès

**Mobiliser**

les connaissances en créant des pages Web attrayantes pour les projets de recherche

<http://uniweb.network>

## Yearly Reviewer List / Liste annuelle des évaluateurs

The high scientific standards maintained by Canadian Acoustics in its papers owe much to the continuing dedication of the journal's reviewers, who give freely of their time and expertise. JCAA is pleased to pay tribute to this contribution by recognizing those who have participated in the review process. Thus, the Editorial Team of Canadian Acoustics acknowledge with particular gratitude the following reviewers who have reviewed papers during the last 12 months.

Les normes scientifiques élevées maintenues par la revue Acoustique canadienne doivent beaucoup au dévouement constant des réviseurs de la revue, qui donnent généreusement de leur temps et de leur expertise. JCAA est heureux de rendre hommage à cette contribution en reconnaissant ceux qui ont participé au processus d'examen. Ainsi, l'équipe de rédaction de l'Acoustique Canadienne reconnaît avec une gratitude particulière les réviseurs suivants qui ont examiné des articles au cours de la période des 12 derniers mois.

**Dr. Umberto Berardi**

Ryerson University  
CANADA

**Dr. Brock Fenton**

Professor Emeritus, Department  
of Biology, Western University,  
London, Ontario  
CANADA

**Mr. Vince Gambino**

Vintec Acoustics  
CANADA

**Dr. Gary S. Madaras**

Rockfon  
UNITED STATES

**Prof. Ramani Ramakrishnan**

Ryerson University  
CANADA

**Tim C Wiens**

GHD  
CANADA

SAVE TIME AT EVERY STAGE FROM MEASUREMENT  
THROUGH TO REPORT

# FOR GOOD MEASURE



Taking accurate acoustic measurements is critical – but not everything. You also need to efficiently document and report on what you're doing to finish a project.

Introducing the new Measurement Partner, a suite of innovative solutions that supports customers through every step of the measurement process. Take remote measurements with its Wi-Fi-enabled sound level meters so sound fields aren't disturbed. Efficiently make integrated annotations with its smartphone field app. And automatically upload data to the cloud to immediately begin using its post-processing software. Completing the solution are a resource-rich learning centre and an online community with blog posts and discussion forums.

See more at [www.bksv.com/measurementpartner](http://www.bksv.com/measurementpartner)

**Brüel & Kjær** 

BEYOND MEASURE

**Bruel & Kjaer North America Inc. (HQ)**

2815-A Colonnades Court

Norcross, Georgia 30071-1588

[www.bksv.com](http://www.bksv.com)

**Canadian Acoustical Association  
Association canadienne d'acoustique**

**2016 PRIZE WINNERS / RÉCIPIENDAIRES DES PRIX 2016**

---

BELL GRADUATE STUDENT PRIZE IN SPEECH COMMUNICATION AND HEARING /  
PRIX ÉTUDIANT BELL EN COMMUNICATION VERBALE ET AUDITION

**Sin-Tung Lau (Wilfrid Laurier University)**

---

RAYMOND HÉTU PRIZE IN ACOUSTICS /  
PRIX ÉTUDIANT RAYMOND HÉTU EN ACOUSTIQUE

**Andrew Lauzon (York University)**

---

CANADA-WIDE SCIENCE FAIR AWARD / PRIX EXPO-SCIENCES PANCANADIENNE

**Marvin Giang and Kevin Zheng (O'Neill Collegiate and Vocational Institute, Oshawa, Ontario)**

---

UNDERWATER ACOUSTICS AND SIGNAL PROCESSING STUDENT TRAVEL AWARD /  
SUBVENTIONS POUR FRAIS DE DÉPLACEMENT POUR ÉTUDIANTS EN ACOUSTIQUE SOUS-MARINE ET  
TRAITEMENT DU SIGNAL

**Graham Warner (University of Victoria)**

---

STUDENT PRESENTATION AWARDS / PRIX POUR COMMUNICATIONS ÉTUDIANTES  
VANCOUVER (BC), SEPTEMBER 21-23, 2016

**Huiwen Goy (University of Toronto)**

**Gabriel Nespoli (Ryerson University)**

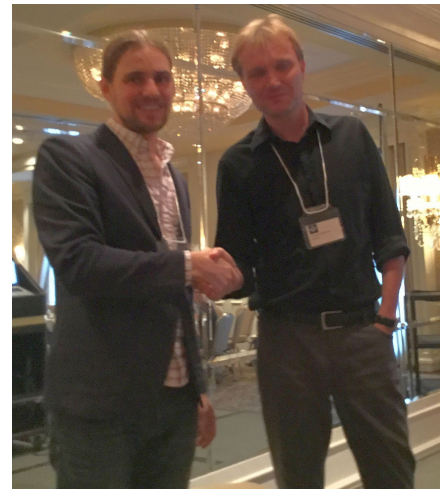
**Brendan Rideout (University of Hawaii at Manoa)**

---



Awards winners Sin-Tung Lau (Bell Graduate Student Prize in Speech Communication and Hearing / Left) and Andrew Lauzon (Raymond Hétu Prize in Acoustics / Right) with Awards Coordinator Hugues Nélisse, at the Awards Ceremony during the Acoustics Week in Canada 2016 in Vancouver

Récipiendaires de prix, Sin-Tung Lau (Prix Étudiant Bell en Communication Verbale et Audition / Gauche) et Andrew Lauzon (Prix Étudiant Raymond Hétu en Acoustique / Droite) en compagnie du Coordonnateur des Prix Hugues Nélisse, à la cérémonie de remise des prix lors de la Semaine de l'Acoustique Canadienne 2016 à Vancouver



Student presentation awards winners Brendan Rideout (left) and Gabriel Nespoli (right), with Awards Coordinator Hugues Nélisse, at the Acoustics Week in Canada 2016 in Vancouver

Récipiendaires des prix des communications étudiantes Brendan Rideout (gauche) et Gabriel Nespoli (droite), en compagnie du Coordonnateur des Prix Hugues Nélisse, lors de la Semaine de l'Acoustique Canadienne 2016 à Vancouver

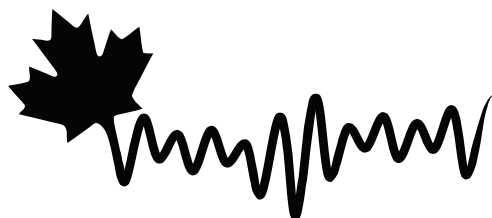
---

## CONGRATULATIONS / FÉLICITATIONS

# Canadian Acoustical Association Association Canadienne d'Acoustique

---

## **PRIZE ANNOUNCEMENT • ANNONCE DE PRIX**



### **CANADIAN ASSOCIATION ACOUSTICAL CANADIENNE ASSOCIATION D'ACOUSTIQUE**

#### ***Prize***

EDGAR AND MILLICENT SHAW POSTDOCTORAL PRIZE IN ACOUSTICS  
ALEXANDER G. BELL GRADUATE STUDENT PRIZE IN SPEECH COMMUNICATION AND HEARING  
ECKEL GRADUATE STUDENT PRIZE IN NOISE CONTROL  
FESSENDEN GRADUATE STUDENT PRIZE IN UNDERWATER ACOUSTICS  
RAYMOND HETU UNDERGRADUATE STUDENT PRIZE IN ACOUSTICS  
THOMAS D. NORTHWOOD GRADUATE STUDENT PRIZE IN ARCHITECTURAL AND ROOM ACOUSTICS  
ALBERT S. BREGMAN GRADUATE STUDENT PRIZE IN PSYCHOLOGICAL ACOUSTICS

#### ***Prix***

PRIX POST-DOCTORAL EDGAR ET MILLICENT SHAW EN ACOUSTIQUE  
PRIX ETUDIANT ALEXANDER G. BELL EN COMMUNICATION ORALE ET AUDITION (2<sup>E</sup> OU 3<sup>E</sup> CYCLE)  
PRIX ETUDIANT ECKEL EN CONTROLE DU BRUIT (2<sup>E</sup> OU 3<sup>E</sup> CYCLE)  
PRIX ETUDIANT FESSENDEN EN ACOUSTIQUE SOUS-MARINE (2<sup>E</sup> OU 3<sup>E</sup> CYCLE)  
PRIX ETUDIANT RAYMOND HETU EN ACOUSTIQUE (1<sup>ER</sup> CYCLE)  
PRIX ETUDIANT THOMAS D. NORTHWOOD EN ACOUSTIQUE ARCHITECTURALE ET ACOUSTIQUE DES SALLES (2<sup>E</sup> OU 3<sup>E</sup> CYCLE)  
PRIX ETUDIANT ALBERT S. BREGMAN EN PSYCHOACOUSTIQUE (2<sup>E</sup> OU 3<sup>E</sup> CYCLE)

***Deadline for Applications:  
April 30<sup>th</sup> 2017***

***Date limite de soumission des demandes:  
30 Avril 2017***

Consult CAA website for more information  
Consultez le site Internet de l'ACA pour de plus amples renseignements  
(<http://www.caa-aca.ca>)



## CadnaR is the powerful software for the calculation and assessment of sound levels in rooms and at workplaces

### Intuitive Handling

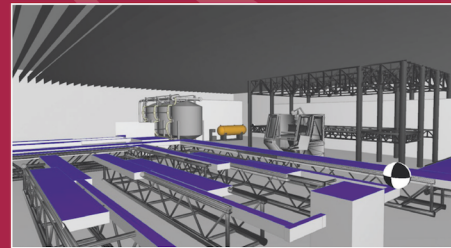
The clearly arranged software enables the user to easily build models and make precise predictions. At the same time you benefit from the sophisticated input possibilities as your analysis becomes more complex.

### Efficient Workflow

Change your view from 2D to 3D within a second. Multiply the modeling speed by using various shortcuts and automation techniques. Many time-saving acceleration procedures enable a fast calculation process.

### Modern Analysis

CadnaR uses scientific and highly efficient calculation methods. Techniques like scenario analysis, grid arithmetic or the display of results within a 3D-grid enhance your analysis and support you during the whole planning and assessment process.



## Fields of Application

### Office Environments

- Process your acoustic calculations and assessments according to DIN 18041, VDI 2569 and ISO 3382-3
- Receiver chains serve as digital "measurement path" and provide you with relevant insights into the acoustic quality of rooms during the planning phase
- Import of DWG-/DXF-/SKP-files (e.g. pCon.planner, AutoCAD, SketchUp)
- Visualization of noise propagation, noise levels and parameters for quality criteria like the Speech Transmission Index STI

### Production Plants

- Calculation of the sound load at workplaces based on the emission parameters specified by the machine manufacturer according to the EC guideline 2006/42/EC while also taking the room geometry and the room design into account
- Tools for enveloping surfaces and free field simulations to verify the sound power of the sources inside of the enveloping surface
- Calculation of the sound power level based on technical parameters such as rotational speed or power



Distributed in the U.S. and Canada by: Scantek, Inc. Sound and Vibration Instrumentation and Engineering  
6430 Dobbin Rd, Suite C | Columbia, MD 21045 | 410-290-7726 | [www.scantekinc.com](http://www.scantekinc.com)

Acoustics Week in Canada 2016  
The Sutton Place Hotel  
Vancouver, British Columbia

  
CANADIAN ASSOCIATION  
ACOUSTICAL CANADIENNE  
ASSOCIATION D'ACOUSTIQUE



## POST-CONFERENCE REPORT

### ACOUSTICS WEEK IN CANADA 2016

September 21-23, 2016

#### Organizing Committee

Conference Co-chairs: Kathy Pichora-Fuller, University of Toronto  
Clair Wakefield, Wakefield Acoustics/RWDI  
Assistant to Co-chairs & Website Manager: Philip Tsui, Wakefield Acoustics/RWDI  
Technical Program Co-chairs: Murray Hodgson, U of British Columbia  
Bryan Gick, U of British Columbia  
Exhibits/Sponsorship Co-chairs: Mehrzad Salkhordeh, dB Noise Reduction  
Bernard Feder, HGC ENGINEERING  
Event Coordination Chair: Maureen Connelly, BCIT  
Proceedings Preparation: Cécile Le Cocq, Université du Québec (ÉTS)  
Jérémie Voix, Université du Québec (ÉTS)  
Student Presentation Prize Coordination: Hugues Nélisse, IRSST

Conference Website: <http://awc.caa-aca.ca>



Semaine canadienne d'acoustique 2016  
Hôtel The Sutton Place  
Vancouver, Colombie-Britannique



## RAPPORT POST-CONFÉRENCE

### SEMAINE CANADIENNE DE L'ACOUSTIQUE 2016

**21 au 23 Septembre 2016**

#### Comité organisateur

Présidents de la conférence: Kathy Pichora-Fuller, University of Toronto  
Clair Wakefield, Wakefield Acoustics/RWDI  
Assistant aux co-présidents & site web: Philip Tsui, Wakefield Acoustics/RWDI  
Directeurs scientifiques: Murray Hodgson, U of British Columbia  
Bryan Gick, U of British Columbia  
Coordinateurs exposants: Mehrzad Salkhordeh, dB Noise Reduction  
Bernard Feder, HGC ENGINEERING  
Coordinateur de la conférence: Maureen Connelly, BCIT  
Préparation des actes: Cécile Le Cocq, Université du Québec (ÉTS)  
Jérémie Voix, Université du Québec (ÉTS)  
Coordinateur des prix des présentations étudiantes: Hugues Nélisse, IRSST

Siteweb de la conférence: <http://awc.caa-aca.ca>



**Thanks to Everyone –  
AWC in Vancouver was a great success!**

**Merci à tout le monde –  
AWC à Vancouver a été un grand succès!**

Thanks to over 170 delegates for making Acoustics Week In Canada 2016 such a great success!

The program featured three plenary invited talks and was packed with a full slate of 121 contributed papers in 21 different sessions. The presentations covered a wide range of topics showcasing the latest work of researchers, consultants and students. Bursaries were awarded to 26 student presenters.



There were 8 generous sponsors that helped to pay for every coffee break and lunch, as well as the opening reception and the banquet, AV and more. The exhibit hall was sold out with 16 exhibitors providing information about and demonstrations of acoustical equipment and services. See the list of sponsors and exhibitors below.



At the banquet, in addition to the traditional presentation of the CAA awards and prizes (see report of Hugues Nélisse), we also congratulated Frank Russo (CAA President) on receiving the 2016 Early Career Award at the 22<sup>nd</sup> International Congress on Acoustics (ICA) held in Buenos Aires on September 5-9<sup>th</sup>. Mike Stinson (left in photo below), long-time CAA member and the Secretary General of the ICA spoke about Frank's achievements and the significance of Frank's ICA award.



We would like to thank the members of the Organizing Committee (see list above) for the hard work and dedication required to plan the conference.

Nous tenons à remercier tout le comité d'organisation pour le travail acharné et le dévouement nécessaire pour planifier la conférence.

Kathy Pichora-Fuller and Clair Wakefield  
Conference Chairs



## Plenary Lectures Séances plénières et scientifiques

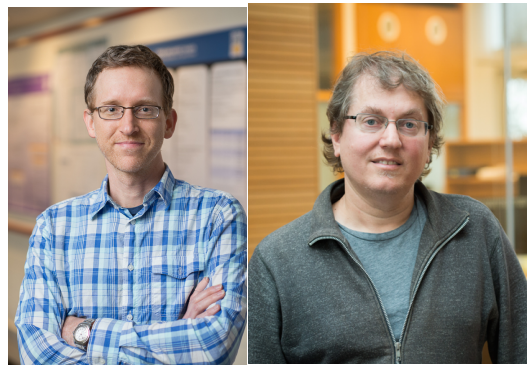
**Judy R. Dubno** (left) from the Medical University of South Carolina talked about age-related hearing loss and how interdisciplinary teams can advance research and practice in acoustics.

**Judy R. Dubno** (à gauche), de la Medical University of South Carolina, a parlé de la perte d'audition associée au vieillissement, et comment les équipes interdisciplinaires peuvent faire avancer la recherche et les pratiques en acoustique.



**Thais Morata** (right) from the National Institute for Occupational Safety and Health (NIOSH) and the Center for Disease Control (CDC) talked about hearing loss prevention in 2016 and modern ways to communicate to the public about hearing health and noise.

**Thais Morata** (à droite) de la National Institute for Occupational Safety and Health (NIOSH), et du Center for Disease Control (CDC) a parlé de la prévention de la perte auditive en 2016 et des méthodes modernes pour parler en publique de la santé auditive et du bruit.



**Bryan Gick** (left) and **Sid Fels** (right) from the University of British Columbia talked about "Interdisciplinary approaches for advancing articulatory speech theory and synthesis".

**Bryan Gick** (à gauche) et **Sid Fels** (à droite), de l'University of British Columbia, ont parlé des approches interdisciplinaires pour l'avancement des théories articulatoires de la parole et de leur synthèse.



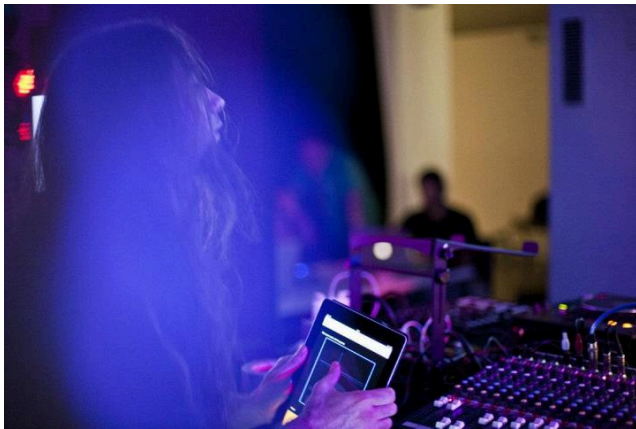
## The Post-banquet Demonstration/Performance

### Performing in Flatland

Victor Zappi, Arvind Vasudevan, Sidney Fels

*Performing in Flatland* is an audio/visual performance inspired by the physics of sound and, in particular, by the theory of pressure wave propagation in space.

Sound is part of our everyday lives, we are constantly immersed in it and our brain is capable of retrieving an impressive amount of information from it. Our relationship with sound is an audio/visual experience. In *Performing in Flatland*, we try to explore this paradigm more deeply, by means of coupling sound and music with a realistic visual representation of how these waves propagate and interact with obstacles.



Victor Zappi (above), Arvind Vasudevan (lower left),  
Sidney Fels (lower right)

Throughout the piece, a virtual representation of a two dimensional physical space domain is projected in front of the audience, where the music played by the performer is visualized as coloured waves travelling on the surface of the screen. Through a digital music interface, the performer interactively manipulates the pixels that compose the propagation domain, drawing

reflecting walls, resonant chambers and more complex dynamic geometric structures. These elements realistically reflect and absorb the sound injected into the domain, producing complex spectral modifications that are used by the performer as primary means of composition. The interaction between the sound sources and the geometry of the domain is also visualized on the screen as clear changes of waves' trajectories and recursive motion patterns, generating a multimodal representation of the involved acoustic phenomena. Furthermore, during the performance these geometries are coupled with different self-oscillating excitation models, to create and play 2D virtual instruments inspired by real aerophones and human voice production.

*Performing in Flatland* is the premiere of a novel digital technology that uses GPU parallel computing to simulate pressure wave propagation in real-time, both sonically and visually. Pressure and velocity values are calculated in the 2D domain using an FDTD solver, implemented in a shading language. Each FDTD cell corresponds to a pixel of a dynamic texture that is updated on the GPU and rendered on screen. The simulation runs at audio rate; at each cycle, the pressure values of a chosen position on the texture are sampled and packed into a buffer, which is then sent to the audio interface to provide a continuous sound stream.

The system was originally developed in the context of research in acoustics and speech. For the performance it has been transformed into an audio/visual instrument and is used together with electronic music controllers as a means of artistic expression.

We would like to thank Dr. Andrew Allen and Dr. Nikunj Raghuvanshi for their help and support. Without their contribution this work would not be possible.

Victor, Arvind and Sid with friends at the banquet before their performance (below)



## Sponsors/Commanditaires

Platinum/Platine



Gold/Or



Silver/Argent



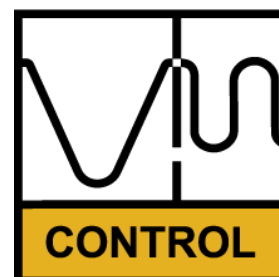
Other/Autres



## Exhibitors/Exposants



VIBRA-SONIC



[www.pcbpiezotronics.ca/acoustics\(en-CA\)](http://www.pcbpiezotronics.ca/acoustics(en-CA))

# When You Need to Take a Sound Measurement



PCB's Broad Range of Acoustic Products  
**High Quality - Unbeatable Prices - Fast Delivery - Best Warranty**

To Learn More Visit: [www.pcbpiezotronics.ca/acoustics\(en-CA\)](http://www.pcbpiezotronics.ca/acoustics(en-CA))

Toll Free 888-424-0033 ■ E-mail [info@dalimar.ca](mailto:info@dalimar.ca)

 **PCB PIEZOTRONICS** INC.

**Dalimar**  
instruments  
A PCB GROUP COMPANY

 **LARSON DAVIS**  
A PCB PIEZOTRONICS DIV.

Your acoustic measurement experts providing a full line of quality microphones, meters, and noise monitoring solutions

**Announcement**  
**ACOUSTICS WEEK IN CANADA**  
**Guelph (Ontario) October 11-13, 2017**



The 2017 Acoustics Week in Canada will be held from October 11-13, 2017 in Guelph, Ontario. You are invited to be part of this three day conference featuring the latest developments in Canadian acoustics and vibration. The keynote talks and technical sessions will be framed by a welcome reception, conference banquet, Acoustical Standards Committee meeting, technical tour and an exhibition of products and services relating to the field of acoustics and vibration.

Features of special interest connected with this conference are:

- Octoberfest celebrations; and
- A Building Code changes and tools workshop by the National Research Council.

Take a few days before or after the conference to enjoy the area! Visit Octoberfest in nearby Kitchener-Waterloo, St. Jacobs Market or the covered bridges.

**Venue and Accommodation** – The conference will be held at Marriot’s Delta Hotel and Conference Centre in Guelph. A block of rooms in the hotel is available at a special conference rate of \$129 per night for reservations made until September 11<sup>th</sup>. Extend your stay and enjoy the local area at the same special rate. Guests have free access to the large MovatiAthletic fitness centre next door. Please refer to the conference website for further registration details: <http://awc.caa-aca.ca>

**Plenary, Technical and Workshop Sessions** are planned throughout the conference. Each day will begin with a keynote talk of broader interest and relevance to the acoustics community. Technical sessions are planned to cover all areas of acoustics including:

- Aeroacoustics
- Architectural and Building Acoustics
- Bio-Acoustics and Biomedical Acoustics
- Musical Acoustics
- Noise and Noise Control
- Physical Acoustics and Ultrasonics
- Psycho- and Physio-Acoustics
- Shock and Vibration
- Signal Processing
- Speech Sciences and Hearing Sciences
- Standards and Guidelines in Acoustics
- Underwater Acoustics



**Abstracts for technical papers are due on or before June 15, 2017** through the conference web site. Two-page summaries for publication in the proceedings are due August 1, 2017. If you would like to organize a session on a specific topic please contact the Technical Chair as soon as possible.

A **special workshop by the National Research Council** will address changes to the National Building Code and the tools available to support it.

**Exhibition and Sponsorship** – The conference offers opportunities for suppliers of products and services to engage the acoustic community through exhibition and sponsorship.

The tabletop exhibition facilitates in-person and hands-on interaction between suppliers and interested individuals. Companies and organizations that are interested in participating in the exhibition should contact the Exhibition and Sponsorship coordinator for an information package. Exhibitors are encouraged to book early for best selection.

The conference will be offering sponsorship opportunities of various conference features. In addition to the platinum, gold and silver levels, selected technical sessions, social events and coffee breaks will be available for sponsorship. Sponsors can have their logo placed on the conference web site within 10 days of their sponsorship. Additional features and benefits of sponsorship can be obtained from the Exhibition and Sponsorship coordinator or the conference web site.

**Students** are strongly encouraged to participate. Students presenting papers will be eligible for one of three \$500 prizes to be awarded. Conference bursaries will also be available to those students whose papers are accepted for presentation.

For **Registration** details please refer to the conference web site.

**Contacts:**

Conference Chair: Peter VanDelden

[conference@caa-aca.ca](mailto:conference@caa-aca.ca)

Technical Chair: Christian Giguere

[cgiguere@uottawa.ca](mailto:cgiguere@uottawa.ca)

Exhibits and Sponsorship: Bernard Feder

[bfeder@hgcengineering.com](mailto:bfeder@hgcengineering.com)



<http://awc.caa-aca.ca>

**Annonce**  
**SEMAINE ACOUSTIQUE AU CANADA**  
**Guelph (Ontario) 11 au 13 octobre 2017**



La Semaine canadienne de l'acoustique 2017 se tiendra du 11 au 13 octobre 2017 à Guelph, en Ontario. Vous êtes invités à participer à cette conférence de trois jours qui présente les derniers développements en acoustique et en vibration au Canada. Les conférences et les séances techniques seront complétées par une réception d'accueil, un banquet de conférence, une réunion du comité des normes acoustiques, une visite technique et une exposition de produits et services liés au domaine de l'acoustique et des vibrations.

Les attraits particulier liées à cette conférence sont:

- les fêtes de l'Octoberfest; et
- Un atelier sur les changements et les outils du Code du bâtiment organisé par le

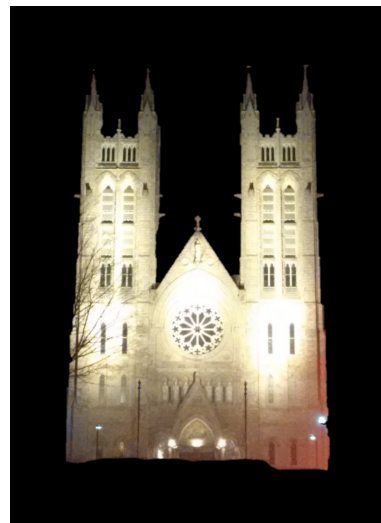
Conseil national de recherches du Canada.

Prenez quelques jours avant ou après la conférence pour profiter de la région! Visitez l'Octoberfest à proximité de Kitchener-Waterloo, le marché de St. Jacobs et les ponts couverts !

**Lieu et Hébergement** - La conférence se tiendra au *Marriot's Delta Hotel and Conference Centre* à Guelph. Un bloc de chambres dans l'hôtel est disponible à un tarif spécial de 129 \$ par nuit pour les réservations effectuées jusqu'au 11 septembre. Prolongez votre séjour et profitez du même tarif spécial. Vous pourrez accéder gratuitement au grand centre de fitness *Movati Athletic* situé juste à côté. Veuillez consulter le site web de la conférence pour plus d'informations sur l'inscription : <http://awc.caa-aca.ca>

**Les sessions plénières, techniques et les ateliers** sont prévues tout au long de la conférence. Chaque journée débutera par une conférence plénière d'intérêt pour la communauté de l'acoustique. Des sessions techniques sont également prévues pour couvrir tous les domaines de l'acoustique, y compris:

- Aéroacoustique
- Acoustique architecturale et de bâtiment
- Bio-Acoustique et Acoustique Biomédicale
- Acoustique musicale
- Contrôle du bruit et du bruit
- Acoustique physique ultrasons
- Psycho- et Physio-Acoustique
- Chocs et vibrations
- Traitement de signal
- Sciences de la parole et sciences de l'audition
- Normes et directives en acoustique
- Acoustique sous-marine



**Les résumés des articles techniques doivent parvenir au plus tard le 15 juin 2017** sur le site Web de la conférence. Les résumés de deux pages seront publiés dans les actes de la conférence à paraître le 1er août 2017. Si vous désirez organiser une séance sur un sujet précis, veuillez communiquer avec le président technique le plus tôt possible.

Un **atelier spécial du Conseil National de Recherches** traitera des changements apportés au Code national du bâtiment et aux outils disponibles pour le soutenir.

**Exposition et Parrainage** - La conférence offre aux fournisseurs de produits et de services la possibilité de faire participer la communauté acoustique par l'exposition et le parrainage.

L'exposition sur le plateau facilite l'interaction en personne et en mains des fournisseurs et des personnes intéressées. Les entreprises et organisations intéressées à participer à l'exposition doivent contacter le coordonnateur de l'exposition et du parrainage pour obtenir un dossier d'information. Les exposants sont encouragés à réserver tôt pour une meilleure sélection.

La conférence offrira des possibilités de parrainage de diverses fonctionnalités de la conférence. Outre les niveaux de platine, d'or et d'argent, des séances techniques, des événements sociaux et des pauses-café seront disponibles pour le parrainage. Les commanditaires peuvent placer leur logo sur le site Web de la conférence dans les 10 jours suivant leur parrainage. Les caractéristiques et avantages supplémentaires du parrainage peuvent être obtenus auprès du coordonnateur des expositions et des commandites ou du site Web de la conférence.

**Les étudiants** sont fortement encouragés à participer. Les étudiants qui présenteront seront admissibles à l'un des trois prix de 500 \$ à décerner. Des bourses de participation seront également offertes aux étudiants dont les communications sont acceptées pour présentation.

Pour plus d'informations sur l'inscription, veuillez consulter le site Web de la conférence.

**Contacts:**

Président de la Conférence: Peter VanDelden

([conference@caa-aca.ca](mailto:conference@caa-aca.ca))

Président technique: Christian Giguere

([cgiguere@uottawa.ca](mailto:cgiguere@uottawa.ca))

Expositions et commandites: Bernard Feder

([bfeder@hgcengineering.com](mailto:bfeder@hgcengineering.com))



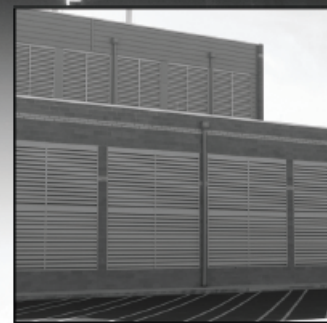
<http://awc.caa-aca.ca>



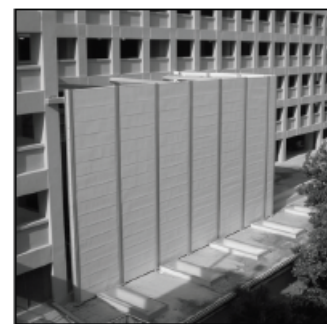
# Environmental Noise Control

*Community friendly solutions  
for chillers and cooling towers*

- Over 50 Years of Proven Design and Performance
- Independently Tested Products
- On Grade or Roof Top Applications
- Maximum Noise Reduction
- Low System Pressure Loss

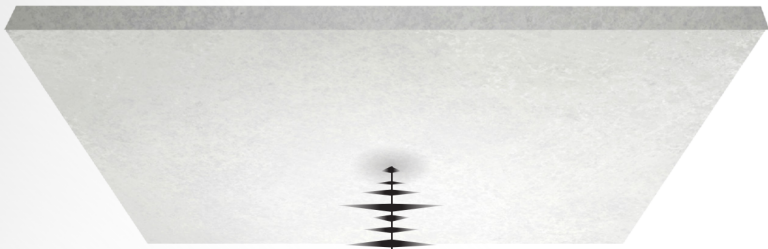


**Central Energy  
Plant Louvers**



**Cooling Tower  
Barrier Wall System**





The Coffee Gulper

The Apple Cruncher

The Ear-Splitting Cackler

The Constant Gabber

The Loud Talker

The Door Slammer

The Weighty Walker

The Heavy Sigher

**Performance AND style.  
Never compromise again.**

Ceiling panels with the style you want and the sound absorption you need. Get the facts at [OptimizedAcoustics.com](http://OptimizedAcoustics.com)

**ROXUL**  
**Rockfon®**

CREATE AND PROTECT®



Call for Papers

# HALIFAX

## **Special issues with regional topics and articles**

Acoustics is a broad subject matter, as you know, that currently employs hundreds of us across the country in fields as different as teaching, research, consulting and others. To reflect such diversity and to -maybe- help each of us discover a new professional in the neighborhood, the Canadian Acoustics journal is currently inviting submissions for a series of special “regional” journal issues from individuals, groups and companies located within the greater-area of Halifax (NS).

## **How to be part of it?**

To contribute to these special “regional” journal issues, authors are invited to submit their manuscript (2 pages maximum), in English or in French, under “Special Issue” section through the online system at <http://jcaa.caa-aca.ca> before **February 28<sup>th</sup> 2017**. The first author must be located in the greater area of the targeted city. Two versions of the same article can be published in the two official languages.

Each manuscript will be reviewed by the Canadian Acoustics Editorial Board that will enforce the journal publication policies (original content, non-commercialism, etc., refer to Journal Policies section online for further details) while welcoming promotion of authors’ expertise, companies services, and consultants' success stories and the like.

## **A true “regional directory” you want to appear in!**

Each of these regional local issues of the journal can be considered as a local directory book for acoustics. They will be published in hardcopies, sent to all CAA national and international members, while electronic copies will be made available in open-access on the journal website. The content of these issues will be entirely searchable and comprehensively indexed by scholar engines as well as by major internet search engines (Google, Bing, etc.). Authors are invited to carefully select their keywords to maximize the visibility of their articles, while ad-hoc advertisement opportunities will be given to pair each article with a one-page full advertisement.

For any question, please contact Sean Pecknold ([pecknold.s@gmail.com](mailto:pecknold.s@gmail.com)) or Michael Kieft ([mkiefte@gmail.com](mailto:mkiefte@gmail.com)). To secure an advertisement for this special issue, please contact our coordinator ([advertisement@caa-aca.ca](mailto:advertisement@caa-aca.ca)).

**Such an offer will only repeat in 7 to 9 years – be sure to submit now!**

<http://jcaa.caa-aca.ca>



**Appel à communications**

# HALIFAX

## **Numéros spéciaux portant sur des sujets régionaux**

Comme vous savez, l'acoustique donne matière à plusieurs sujets d'ordre général et créer des centaines d'emplois au pays, et ce, dans différents secteurs tels que l'éducation, la recherche, la consultation professionnelle et autres. Afin de bien refléter cette diversité et peut-être même à faire connaître davantage les professionnels de notre voisinage qui œuvrent dans le domaine, l'Acoustique canadienne fait un appel à soumettre une série d'articles provenant de personnes, groupes ou compagnies qui font partie de la grande région de Halifax (NS).

## **Comment en faire partie?**

Pour contribuer à un de ces numéros « régionaux », les auteurs sont invités à soumettre un article (de 2 pages maximum), sous la rubrique « Numéro spécial » dans notre système en ligne au <http://jcaa.caa-aca.ca> avant le **28 février 2017**. Le premier auteur devra faire partie de la grande région de Halifax. Il est possible de soumettre un même article dans les 2 langues officielles.

Chaque article sera révisé par le comité éditorial de l'Acoustique canadienne qui veillera à ce que les politiques de publications de la revue soient respectées (contenu original, contenu non commercial, etc. – voir les politiques de la revue pour de plus amples détails) tout en accueillant les articles qui font la promotion de l'expertise des auteurs, des services offerts par les compagnies, les réussites de consultants et autres sujets du même ordre.

## **Un vrai « répertoire régional » dans lequel vous voulez paraître!**

Chacun de ces numéros spéciaux régionaux pourra être considéré comme un répertoire des noms et services locaux liés à l'acoustique. Ils seront publiés en format papier et envoyés à tous les membres nationaux et internationaux de l'ACA. Une version électronique sera aussi disponible en ligne sur le site internet de la revue. Le contenu de ces numéros sera indexé, donc facilement trouvable au moyen de moteurs de recherche majeurs, tels Google, Bing, etc.). Les auteurs sont invités à bien choisir les mots clés pour maximiser la visibilité de leur article. Des opportunités de publicité ad hoc seront offertes pour jumeler chaque article avec une page complète de publicité.

Pour toutes questions, vous pouvez communiquer avec Sean Pecknold ([pecknold.s@gmail.com](mailto:pecknold.s@gmail.com)) ou Michael Kieft ([mkiefte@gmail.com](mailto:mkiefte@gmail.com)). Pour réserver un espace de publicité dans un de ces numéros spéciaux, veuillez communiquer avec notre coordonnateur ([advertisement@caa-aca.ca](mailto:advertisement@caa-aca.ca)).

**Une telle offre ne se reproduira pas avec 7 ou 9 ans, assurez-vous d'en profiter maintenant !**

<http://jcaa.caa-aca.ca>



## MINUTES CAA COMMITTEE ON STANDARDS

2016 September 20, 19:00 h,

Vancouver, BC;

Acoustics Week in Canada

**Present:** Tim Kelsall, Chair. Stephen Keith ( by phone), David Quirt, John Swallow,

Joining while in progress: Bill Gastmeier, Peter VanDelden, Andy Metelka

**Observers:** Henk de Haas, Virgini Senden

1. **Welcome:** Tim Kelsall

2. **Minutes:** John Swallow - June minutes were approved (attached at the end of this document)

3 **Approval of Agenda:** Consent by all present

4. **Report from CAA Board - Tim Kelsall**

Tim had just attended the board meeting. (Note Committee voted, by ballot, approximately 4 years ago to publish our Guide to Standards and put it on the CAA website about two years ago.)

a) **CAA Website.** DQ submitted request to SubCtte chairs, approx Sept 7, asking what changes need to be made to the Website to bring it up to date? Responses received from Gastmeier, Keith, Quirt, Lixue Woo. They were requested to provide any other updates – particularly anything covered by legislation in Canada, also any other useful or relevant documents.

DQ reviewed the responses, there are few changes to be made; also noted that where US standards are to be adopted a French version will not exist, while for ISO Standards a French version will exist. See Item 1 attached

a) **Marketing:** TK asked how to determine the number of downloads from this site.

b) **CAA Standards Voting Body Qualification**

TK noted it will need ratifying in a short while; that establishing a Quorum is a problem.

c) Journal will publish our meeting minutes

1. **5. Sub-Committee Reports** (Written reports are available on the Standards page at the CAA website)

a) **Environmental** – See BG Report 2 attached. Note major changes to the way Ontario MOECC will evaluate wind turbines, with emission ( IEC Standard ) and auditing procedures for Immission , very stringent. MOECC removed authority from the Municipalities in an unusual manner; new procedure NPC 350 for immission. If Regulation not met, may require shutting down the wind turbine.

b) **Wind Turbine** – Brian Howe – no report ( ed note: seems to be covered above)

c) **TC 43 / SC1** see SK report 3 attached. Note meeting occurred in Sept 2016.

d) **TC 29 / SC** See LW report 4 attached.

e) **Z 107.10 Editorial** Cameron Sherry. No Report. DQ reviewed:

f) **Building Acoustics**, NRC has concentrated on updates to NBCC 2015. The 2015 version for Sound Isolation ( i.e. STC ) is a mix of ISO and ASTM standards. Canada has been involved in the development of the new ISO standard , the NBCC reflects the coming changes in ISO Standards and is thus at the leading edge. A new version of the Guide to use with NBCC, with calculations of flanking paths, is now up on the NRC Website, there will be more before Dec 2016. Calculations for masonry, concrete construction will be complete early in 2017, wood frame later, no date set. Fall 2017 NRC will do seminars on the use of the Guide. Expect all material to be published in advance. See DQ Report 5 attached

Work is being done by others on Impact Noise. Chair now vacant, previously USA.

g) **ISO TC 108 SC4**, Human Response to Vibration. See Report 6 attached by AJ Brammer.

h) **Loudness Evaluation** – Colin Novak, No Report.

**8 New Business** - None

**9 Next Meeting.** Normally held in Spring, next meeting possibly with CSA.

ACTION: TK, coordinating with Christian Giguere.

**10 Adjournment:** 20:00 h

Minutes by John Swallow, [jswallow@swallowacoustic.ca](mailto:jswallow@swallowacoustic.ca)

## Sound and Vibration Instrumentation *Scantek, Inc.*



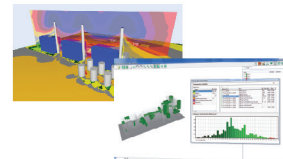
### Sound Level Meters

Selection of sound level meters for simple noise level measurements or advanced acoustical analysis



### Vibration Meters

Vibration meters for measuring overall vibration levels, simple to advanced FFT analysis and human exposure to vibration



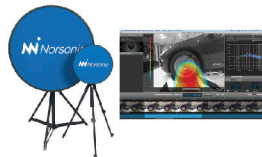
### Prediction Software

Software for prediction of environmental noise, building insulation and room acoustics using the latest standards



### Building Acoustics

Systems for airborne sound transmission, impact insulation, STIPA, reverberation and other room acoustics measurements



### Sound Localization

Near-field or far-field sound localization and identification using Norsonic's state of the art acoustic camera



### Monitoring

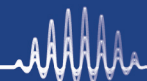
Temporary or permanent remote monitoring of noise or vibration levels with notifications of exceeded limits

## Scantek, Inc.

[www.ScantekInc.com](http://www.ScantekInc.com)

800-224-3813

Sales, Rental, Calibration





## STANDARDS MEETING

June 9, 2016

John Kean Boardroom, CSA Office, 178 Rexdale Blvd, Toronto.

### Minutes of the Meeting

1. **Welcome:** The meeting started at 2:00 pm. Priya Malik went over CSA safety. Chair T. Kelsall welcomed members and guests, with a brief introduction of attendees. There were technical difficulties with the online connections and the members participating by teleconference joined at 2:25 pm.

<b>In Person:</b>		
Tim Kelsall	Hatch (CHAIR)	tim.kelsall@hatch.com
Bill Gastmeier	HGC Engineering	bgastmeier@hgcengineering.com
Christian Giguère	U. Ottawa	cgiguere@uottawa.ca
David Quirt	Consultant	JDQ.acoustics@bell.net
Peter VanDelden	RWDI Consulting	peter.vandelden@rwdi.com
<b>Online:</b>		
Tony Brammer	Enviro-Health Solutions	Anthonybrammer@hotmail.com
Stephen Keith	Health Canada	skeith@hc.sc.gc.ca
Jack Davis	Albert Utilities Commission	Jack.Davis@auc.ab.ca
<b>Guests</b>		
Andy Metelka	SVS Canada Inc.	ametelka@cogeco.ca
Ric Doedens	K.R. Moeller Associates Ltd.	rdoedens@logison.com
Regrets: Lixue Wu		

2. **Appointment of Minutes Taker:** Kristen Abels
3. **Approval of Agenda:** Approved as written (all in favor).
4. **Approval of Minutes:** Not applicable. Minutes were not recorded from the last meeting (Halifax 2015). Audio recording available.

## 5. Update since last meeting

### a. CAA 101

- i. Translation: No progress. It was discussed that there is little reason to have a French introduction to an English document. A volunteer would need to be found to translate.  
It was agreed that it would be very difficult to translate and to keep translations up to date. The main concern is the ANSI standard text and ASTM. There is the possibility of putting commentary in French.
- ii. Website / Journal Publication: **Action Item:** C Giguère will handle cleaning up list of standards (which currently contains out of date references).
- iii. Marketing of standard: Confined to Canadian Acoustics and Conferences. It was agreed that it would be a good way for someone more junior in the organization to get exposure. Looking for a volunteer to take on the marketing.
- iv. Sponsorship? Need for sponsorship is limited.  
Thanks to CSA for allowing use of John Kean Boardroom for this meeting. The benefits of having the CSA and CAA meetings together are noted.
- v. T Kelsall explained new rule of limited terms for CSA Chair and Vice-Chair.

### b. CAA Standards Voting Body Qualifications: Nothing to vote on at the moment.

## 6. Items from CAA board (Bill Gastmeier): No action items identified.

## 7. Update From Subcommittees (Written reports are available on the Standards page at the CAA website)

### a. Environmental Noise (Bill Gastmeier, written report)

- i. NPC 300 issues of the consideration of vacant lands as noise sensitive receptors for industrial approvals and municipal uncertainty around handling Class 4 acoustical environments.
- ii. MOECC Modernization Programme consideration of expanding EASR programme to include medium sized commercial and industrial facilities would streamline the process; Concern about P. Eng not qualified to declare a complete and accurate study.
- iii. MOECC has updated Noise Guidelines for Wind farms (additional Noise Impact Assessment analysis requirements).
- iv. Comments on the draft update of the MOECC Compliance Protocol for Wind Turbine Noise due June 16th 2016.
- v. AWMA conference to be held Oct. 26<sup>th</sup> 2016 in Waterloo, ON; can submit papers now.
- vi. FCM-RAC presented a successful workshop on noise and vibration issues relating to land use planning in proximity to railway lands in Oct. 2015, which promoted a review of proximity Guidelines for New Development in Proximity to Railway Operations.
- vii. Alberta Update Submitted by Jack Davis (written report):
  1. Low noise concerns from Drilling and Service Operations, as drill counts at 5% utilization rate.
  2. Phase out of coal-fired power plants and creation of framework for increasing green energy initiatives.
  3. Recent approval of Grizzly Bear Creek – 2<sup>nd</sup> wind farm with major hearing dealing with health issues, infrasound, Rule 012 issues (40 dBA  $L_{eq}$  night-time permissible sound level). 46 dBA was the highest measurement; no judgement made on acceptability of those levels, however a Health Canada Study cited that there were 2 papers generated with discussion that 46 dBA was an acceptable level (could have been misinterpreted during the hearing). **Action Item:** J Davis will read that study and ensure there is no misinterpretation.
  4. J Davis is looking to establish a protocol for comprehensive sound level surveys and address the following issues: Determination of who owns the noise space when it comes to a complaint, as well as the issue of wind farms that have been approved but being granted extensions on their approval, and residents who are unaware of future wind farm developments. Another issue involves wind turbines being built upwind of wind farms (not jurisdiction of AUC as much as it is going to court).
  5. J Davis thought that the document ‘Graduated scale for wind in terms of permissible sound level’ (2008) would be taken off the books. Similar to Wind Noise Masking, which J Davis would be reluctant to promote, as it has no conditions. There has never been an application.

6. Discussion about the use of  $L_C - L_A$  (dBC – dBA) measurements for low frequency noise with wind turbines (Alberta Energy Regulator Directive 038).
  7. **Action Item:** J Davis working on supplement to Rule 012: Reading ‘Wind Turbine Noise’ by Leventhall and Bowdler and suggests that Chapter 7 by David Hessler would be of interest. Will read through that, as well as NPC 350 and put something together.
- b. Wind turbines Brian Howe (written report included in Environmental Noise report)  
Discussed along with Environmental Noise.
  - c. CAC TC43 SC1, (Stephen Keith, written report) to report on ISO
    - i. Representation: New member for the Shooting Noise Standard (Ann Nakashima of Defence Research and Development Canada); Total 2 project leaders, 1 international secretary, 17 subject matter experts; 1 new member application for ISO Standards for Ducted Silencers (Karl Peterman of Vibro-Acoustics); Nicolas Sylvester-Williams of Aercoustics interested in joining general committee. No Canadian participation in working group on Detection of Tones (Colin Novak and Helen Ule interested in joining)
    - ii. Workload: reviewed 2 drafts (389-1, 12124) from ISO/TC43 main committee; Abstained on draft for hearing aid fitting; Final drafts on ISO 389-3 and ISO 389-ISO/TC43 SC1; Reviewed 2 drafts (362-3, 17201-6); Abstained on 2 drafts due to lack of expertise (tyre and road surface noise); Approved final drafts of ISO 1996-1 (main changes with community tolerance index), ISO 6926, ISO 16254.
    - iii. Upcoming ISO meetings – attendance at working groups, no Plenary this year. Thanks to Standards Council of Canada, Akoustik Engineering and Hatch for travel subsidies for meetings.
    - iv. In the advisory panel, some standards refer to the ISO standard that defines the reference quantities of acoustics, which refers to the neper instead of the decibel (which can lead to 10% error). **Action Item:** Must correct standards to ensure people do not use Nepers instead of dB.
  - d. IEC, Instrumentation (Lixue Wu, written report)  
T Kelsall read the report provided by L Wu. No discussion.
  - e. CAA101 / Editorial (Cameron Sherry and David Quirt, verbal report by D Quirt)
    - i. T Kelsall already presented brief report on status – Unchanged and posted on website. French Translation has not proceeded any further. For all the Standards that are available in French, there is a French abstract available for the document; headings and subheadings are in both English and French, but still no formal French version available. At an impasse until a long-term sponsor is found to cover the substantial cost of translation of summaries for all of the ANSI documents. No volunteers found (should be taken to the CAA board for discussion).
    - ii. Subcommittee chairs should review the standard, as there are pertinent changes in building acoustics. **Action Item:** The editorial subcommittee should send a circular to other subcommittees to request them to start a review. D Quirt will do so.
  - f. Building Acoustics ISO/TC43/SC2 and ASTM E33 (David Quirt, written report)
    - i. Meeting in Milan last year (no Canadian delegate, as D Quirt had travel issues)
    - ii. Process for creating new ratings for sound transmission has started again with new chair. A working group is in place (should expect a working draft in coming year).
    - iii. ISO 15712 series: document changes approved in 2015 and published in January 2016. Current version of National Code (which makes use of apparent sound transmission class of the complete system rather than that of the separated assembly) hasn’t reached Provincial Code, but expected to over next 2 years. NRC is in process of creating documents to deal with the code change (expected that the remainder will be published over the next 18 months). It is possible that provinces will be looking at adoption of 2015 version of the Building Code before then (could lead to confusion). Assumed that NRC will provide seminars to train people on necessary details.
    - iv. ISO 15712 series referenced in 2015 Building Code are almost obsolete. It was decided in Milan to drop the obsolete ISO 15712 series and replace it with ISO 12354 (harmonized with European Standards). Canada voted affirmative in the ballot last month. In the next 2 or 3 months, the updated name of ISO standard must be included in any interim changes of the Building Code, and the committee dealing with revisions in the 2020 code will get started next month (to add revisions for insulation and impact sound).
    - v. Issues in ASTM E33: D Quirt commented on the problem that the building industry is familiar with the ASTM standards and ratings (STC rating in particular). Now there is a switch to ASTC, which uses an

ISO Standard. Brad Gover from NRC attended the last E33 meeting, and has attempted to get them to produce a guideline document on how to use the ISO standard (there is an NRC document available). However, ASTM is now looking into Structure-borne sound transmission. Other key issues being addressed are listed in the written report.

- vi. R Doedens adds a quick note to ASTM: work underway to update E1130, T2638, E1374, E1573 (related to interior office acoustics), and there is a new task group working on establishing performance guidelines for sound masking systems.

R Doedens wants to work alongside with CAA to move the sound masking industry and interior acoustic design forwards. Sound masking systems have evolved and can now precisely control minimum background sound levels to make entire acoustic design easier and more cost effective (so that over-insulating/building is not required).

R Doedens also expresses concerns that sound masking industries are overselling products and that key members are guilty of false advertising (suggesting product provides total acoustic performance without use of complimentary products/treatments). Discussion of approaching INCE or CISCA.

g. Human Vibration ISO TC 108/SC4 (Tony Brammer, written report)

- i. No documents have changed. There is a potential update on ISO 2631, and a working group is making progress on developing a test method for estimating the effectiveness of seats (ie. for high-speed boats). A Technical Report on a review of the frequency weighting used to predict the occurrence of hazards to the hands is in preparation.
- ii. ISO 5349-2 (which is included in the omnibus standard) has been revised and should be included in the next update of the standard.
- iii. ISO 10819 has been approved as international standard, but an amendment to the new standard is being undertaken.
- iv. T Brammer shares the decision made at this morning's CSA meeting to adopt several key ISO Health Related standards into CSA and CAA standards (ISO 5349-1/2, ISO 10819).

h. Loudness Evaluation – Colin Novak

- i. No update. Members agree to contact Helen Ule to ask if she is interested in joining the group.

8. New Business

**Major Item:** Starting over with our one standard and making sure it stays up to date.

- 9. **Next Meeting and Adjournment:** T Kelsall reported next meeting will be in September 2016 in Vancouver during Acoustics Week in Canada, in conjunction with the CSA committee meeting (tentative date is September 21<sup>st</sup> 2016).

T Kelsall mentions he will be chairing a session on Acoustical Standards at Acoustics Week in Canada September 2016 in Vancouver, and would appreciate papers on acoustical standards to pull together a session (abstract submission deadline is June 15<sup>th</sup>).

The meeting adjourned at 3:25 pm.

# CANADIAN ACOUSTICAL ASSOCIATION

## Minutes of the Board of Directors Meeting

Held at Sutton Place Hotel, Vancouver

20 September 2016

Attending in person: Frank Russo (chair), Bill Gastmeier, Dalila Giusti, Hugues Nélisse, Roberto Racca, Mehrzad Salkordeh, Kathy Pichora-Fuller, Jérémie Voix, Bryan Gick

Attending on-line: Michael Kieft, Joana Rocha

Frank called meeting to order at 15:06

As first order of business Frank called for approval of the minutes from the April BoD meeting, noting that they had already been reviewed by Board members and published. Approval moved by Mehrzad, seconded by Bill. Carried unanimously.

### **President's report (Frank Russo)**

Frank reported growth of the Association's footprint on social media under his present curation, with 122 followers on Twitter and 547 on LinkedIn. He pointed out that, as stated from the outset, he would not be continuing in the role indefinitely. A post-doc and long-time student member of the Association, Huiwen Goy, had agreed to take the role of social media coordinator.

Frank reported on the ICA meeting in Buenos Aires that he attended as Canadian co-representative with Michael Stinson; Canada had 8 votes out of 70, split between the two representatives. Frank noted that ICA made a financial profit at their 2013 meeting in Montreal that was shared with ASA, thanks to a registration fees sharing agreement brokered with the host organization. That could be a possible paradigm to consider for future joint meetings with ASA (past 2018) and other organizations. Frank also reported that ICA is working with UNESCO involvement to have 2019 recognized as the Year of sound, patterned after the International Year of Light in 2015. Major outreach is planned if that happens, with sponsorship sought from big names. Future ICA meetings will be held in Aachen, Germany (2019) and Gyeongju, Korea (2022). An ICA budget is available to support Special Symposia that are advanced through national member organizations (\$1500-2000 per instance).

Board renewal: Kathy is leaving this year; Christian Giguère (past president) is in contact with possible candidates to replace her, to be confirmed by the time of the AGM so that a name can be put forward. Next year a number of turnovers is anticipated; Frank himself is to step down soon from his role of President. Christian will be looking for new recruits to replace next year's outgoing members, as per usual practice of having a full slate to propose at the AGM rather than relying on there being sufficient nominations from the floor.

Future meetings: Frank reported that Peter VanDelden had been making excellent progress in preparing for AWC-2017, which included securing keynote speakers, sponsorships, and a competitive rate for the conference venue. Peter would join the meeting later for a more detailed update in person. Frank also reminded the Board that the CAA had entered into an agreement with ASA to co-host a meeting in Victoria in the fall of 2018, which would take the place of AWC-2018. The Association's MOU with the ASA states that the CAA will not take on any financial obligations in the running of the conference nor will share in any profits. Frank noted that the CAA had been asked to suggest any special sessions by 28 September 2017, and that Mike Stinson (current president of the ASA) had also raised the possibility of having joint CAA and ASA chairs for each session.

Trade association proposal: Frank indicated that RWDI had contacted him about the proposed formation of a national organization of acoustics consultants, which would not compete with the CAA and in fact would endeavour to swell its ranks. That group would set accreditation criteria and require membership in the CAA as a condition. Steve Meszaros, one of the two RWDI consultants spearheading the initiative, would address the Board later during the meeting. There was some general discussion regarding what standards would be required for accreditation, but the Board agreed to wait for the presentation.

### **Update on CAA 2016 conference (Kathy Pichora-Fuller)**

Kathy informed the Board that the hotel room quota had been met and the preliminary budget looked very positive. 164 individuals had currently registered, of which two-thirds were full 3-day registrations. The technical program was entirely filled and all levels of sponsorship had been subscribed. Philip Tsui from RWDI and Maureen Connelly from BCIT provided great logistic support. A profit of around 10,000\$ was estimated, gross of any adjustments for the membership component of non-member registration fees which technically was a flow-through to the CAA. Kathy mentioned that it had not been possible to verify easily the actual membership status of registrants applying for member's rates. After discussion it was agreed that a membership database check would be run before registration began in the morning so that any registrants whose membership

status did not match their application could be notified. Dalila pointed out that membership benefits should be discounted from the profit of the conference.

Kathy indicated her willingness to draft a full outline of a conference organizers' manual meant to facilitate the task of future organizing committees. Input from others would be needed for sections on sponsorship and exhibits organizing. She planned to begin the task right after the conference.

26 students received a subsidy package which included a free night at the hotel (paid directly from the conference budget) and admission to the conference. This was subject to the applicant presenting a talk as first author and submitting the corresponding proceedings paper. Travel costs were the responsibility of the student or their supervisor. Dalila recommended that a budget analysis of this approach be performed before considering it as a paradigm to be endorsed for the future.

#### Secretary's report (Roberto Racca)

Roberto provided and reviewed the current tally of Association members and Canadian Acoustics subscribers as summarized in the table below, which shows by comparison the numbers reported at the April 2016 and October 2015 meetings.

Category	Paid-up 2016  (as of 18 Sept. 2016)	Paid-up 2016  (as of 1 April 2016)	Paid-up 2015  (as of 5 October 2015)
Regular member	148	133	165
Emeritus	1	1	1
Student	33	18	22
Sustaining subscriber	26	26	28
Indirect subscribers			
- Canada	6	5	3
- USA	4	4	6
- International	4	3	5
Direct subscribers	3	3	4
<b>Total</b>	<b>225</b>	<b>193</b>	<b>234</b>

Roberto noted that the numbers appeared to be growing again compared to the slump we saw in April, and were nearly on par with the overall tally of a year before save for a shift from regular to student memberships. The increase in the latter could be attributed at least in part to the successful canvassing of students to join the Association shortly before the September conference so they could benefit of bursaries to present their work. Difficulties with the on-line membership renewal system might still account for some loss of membership through failed transactions that frustrated people. Overall, however, it appeared that the on-line membership management process now worked smoothly in the large majority of cases and the sequence of automated e-mail reminders as memberships are about to lapse generally resulted in timely renewals with no intervention.

During the registration process for this year's conference the Secretary was called to assist in various cases with the verification of membership status of student registrants to establish eligibility for travel support or student paper competitions. Roberto stated that in his view this revealed a more pervasive issue with the isolation between the conference registration and the CAA membership databases. He suggested that were the two databases linked, on-line conference registration application forms could be directly informed (in terms of rates offered etc.) by the status of the applicant. Conversely, a conference registration as a non-member could lead directly to the creation of a corresponding membership record. In discussion of this point, Jérémie explained how the process of creating memberships for non-member registrants is handled by sending e-mails to all the latter asking them to create user accounts for themselves within one week, that he then converts to members (always full, not students). If they do not accept, then they do not get the benefit from their higher registration.

Roberto went on to mention that some members, as in the past, had expressed the wish for special categories of membership recognizing retired status or other situations of lack of gainful employment; interest had also been expressed in the option of paying reduced rates for longer-term memberships. On a more conceptual level, members had expressed confusion at the inconsistent use of the terms “subscriber” and “subscription” in much of the template wording of the on-line membership management site. This ambivalence between subscription and membership became more critical in the case of institutional subscribers who would mistakenly assume that a membership in the Association (e.g. in the name of the contact person) would be created or renewed as part of the subscription. In discussion, Jérémie indicated that some templates on the registration site had reverted to earlier wording after an update (in their proper format they provided in fact a clearer distinction between subscription and membership) and he would now restore the appropriate versions. The issue of the request for alternative levels of membership was noted and Frank indicated he would contact directly some advocates for this change requesting their input in suggesting categories.

Lastly Roberto reported that the handling of paper based subscription renewals (generally limited to indirect subscriptions managed by an agency) had still resulted this year in a couple of lapses in the updating of subscription status and missed issues of the Journal due to communication delays in informing the Secretary of paper renewals (delivered to a PO box in another geographic location). The situation had somewhat righted itself after at least one subscription agency started sending all postal mail directly to the Secretary.

Frank moved to approve Secretary's report; Dalila seconded. Approved unanimously.

#### **Standards committee update (Tim Kelsall, joining briefly at 17:15)**

Tim expressed willingness to remain as chair of the Canadian standards committee. Only one standard being handled, namely a summary of all world standards in acoustics that are pertinent to Canada. Translation into French is an issue except for those original third-party standards that already have an official French version (USA standards do not); in practical terms it is not a major drawback, but in terms of Canada being bilingual it is a shortcoming. Jérémie asked Tim to provide the minutes of the standards committee meeting for insertion in the Journal.

Frank moved that Tim be confirmed as chair; Dalila seconded. Passed unanimously.

#### **Guelph 2017 AWC update (Peter van Delden, joining briefly at 17:25)**

Peter reported that the selected conference hotel (Delta) is well sized for the event and with convenient rooms placement. Main themes being pursued are hearing conservation, noise control, and in-air acoustics. Plenary speakers are being identified in these areas. NRC had expressed interest in delivering a talk on architectural acoustics on the Thursday (exhibition day); Peter noted that parallel sessions on that day would be on unrelated topics to the NRC presentation. Frank recommended that the conference strive to solicit content from a broad cross section of the topics represented in the Journal. Peter also indicated that the hotel would be available the day before the conference for workshops or training sessions, that should be non-promotional in nature. There was some general discussion about the need for a standard of scientific quality to be established for proposed courses or workshops.

Finance and registration being organized by Dalila. Estimated expenses \$55,000 of which \$25,000 for food; no cost for meeting rooms if block of 110 room nights is met; \$129/night rate. Estimated revenue from registration \$45,000; sponsorships and exhibits \$15,000. Already expressions of interest from potential sponsors. Social events to include opening reception, banquet and possibly technical tours.

Peter indicated that the organizers were looking at possible new avenues of advertising the event, including list servers and newsletters from other associations. Web site content was already being developed and would be published online as soon as the current conference's content could be superseded. There was some discussion about organizing an outreach event to students and general public, e.g. a public lecture.

#### **Brief presentation on proposed trade association (Steve Meszaros, joining briefly at 18:00)**

Steve briefed the Board on the concept of a trade association of acoustics consultants being spearheaded by RWDI. Currently looking for interest across the industry, with a plan to put together a framework and charter and have potential members review it. Proponents of the new entity don't see it at all as a potential competitor to the CAA, as it would be more focused on the technical trade aspects and less on the scientific. Likely the charter of the trade association would impose a requirement for principal consultants of member companies to belong to the CAA (a paradigm implemented by a similar trade group in Australia for the corresponding national acoustical association). The purpose of the trade group would be to promote the importance of acoustic design in everyday practice, and make the public more aware of the importance of the sector. Also would recommend standards of practice and establish minimum competency requirements for membership, as well as enhancing the status of acoustics as a branch of engineering (e.g. facilitate ability of acousticians to achieve a P.Eng.)

Frank commented that he would not want the CAA to lose its inclusive status as both scientific and technical association; there had therefore to be a complementarity of purpose with the trade group. There was some discussion regarding the group's

proposed ability to bestow accreditation and set standards on membership; in particular, how would the integrity and credibility of the process would be assured. Bill noted the importance to consider the National Association of Acoustical Consultants (NAAC), a well-established entity in the USA with inroads in Canada, since the new group could be redundant to its goals.

Frank expressed general appreciation of the principles of the proposed trade association but noted the need for further development of the framework; at this stage the CAA would not explicitly endorse the initiative but would remain open to potential future collaboration.

#### **Treasurer's report (Dalila Giusti)**

Dalila presented financial summaries for the current year and proposed budget for 2017. She noted that a significant new addition to the 2017 budget is an increase to the Student Subsidy from \$2,500.00 to \$10,000.00 following deliberation at the previous Board meeting, and pointed out that if the full \$10,000.00 is spent the Association might be posting a deficit. This may not be the case if healthy membership revenues are maintained, and/or the 2016 Conference has a profit, and/or the full amount allocated for Student Subsidy is not spent.

Dalila remarked that awards are substantially under-represented this year due to apparent low interest in applications. She also expressed some concern about the approach taken by the 2016 conference in providing student support, as it is not easily reflected as a budget item and makes it difficult to make decisions on allocation of funds for student travel in future events. Dalila looked for opinion of the Board on whether to continue including the travel subsidy in the conference budget, given the "in kind support" alternatives being explored. General agreement was that we should keep the \$10,000 in place.

There are ongoing issues with securing advertising revenue, due to some advertisers not paying their invoices. Membership and sustaining subscribers' dues are remaining about steady. Production costs for the Journal are lower than in the past. Next year the CAA's membership in ICA will be up for renewal and fees due; likely to renew for 3 years.

Investments did very well last year, but the returns are likely to be lower this year. Tax return was filed in May 2016 and included an engagement review report.

Bill moved to approve the report; Mehrzad seconded. Carried unanimously.

Dalila indicated that she would wish to start grooming a successor for the treasurer's position, in an overlap model similar to what was done with the editor's role.

#### **Award coordinator's report (Hugues Nélisse)**

Report to stand as a submitted document without discussion.

A notable point made in the report was that this year many of the awards went unclaimed for lack of any applicants. In this light the CAA's position with regard to whether any new awards should be created has to be reviewed and assessed.

#### **Editor's report (Jérémié Voix)**

Jérémié requested funding for implementing DOI (Digital Object Identifier) indexing of journal content. The cost moving forward would be USD 275 / year for all new content; the cost for retroactive indexing of all past issues could be up to USD 3,000. Board agreed to allocate \$5,000 for the project. Dalila will reflect this in the budget.

The question of whether to execute an outstanding publishing agreement with EBSCO as previously discussed has remained open due to uncertainty on official postal delivery address, and now to the possibility of the journal potentially going to Springer as publisher (see other item below).

Jérémié informed the Board that a secure web site will be implemented for the Journal; this will require a certificate costing USD 100 yearly.

Impact factor evaluation of the journal Canadian Acoustics by Thompson-Reuter yielded a very low rating (ranking at the bottom of the acoustics category). It may still be better than having no impact rating at all, but Jérémié said he would be also considering a rebuttal. On this note Jérémié called broadly for contribution of good quality articles to the Journal.

Jérémié introduced the question of whether we should go to Springer for publishing Canadian Acoustics (as Australian Acoustics did in 2015). The transition would affect the current open access status enjoyed by the journal for issues other than the current one. Jérémié suggested that the members be polled for an opinion of where the journal should be headed – continue trying to be a scientific publication or change to more of a newsletter. After a brief discussion the BoD recommended that the journal advisory board discuss the issue and provide recommendations; they will then be reviewed in a special session.

#### **Adjournment**

Motion to adjourn by Frank, seconded by Dalila. Meeting ended at 18:53.



Sutton Place Hotel, Vancouver, British Columbia  
Thursday, 22 September 2016  
17:00-18:00

**1. Call to Order: 17:00 – about 25 members**

Frank Russo (President) welcomed participants and noted that the ongoing 2016 Acoustics Week in Canada conference was a resounding success, with some 170 confirmed registrants.

**2. Approval of previous minutes:**

*MOTION to approve the previous AGM's minutes: moved by Stan Dosso, seconded by Jérémie Voix, carried unanimously.*

**3. President's Report (Frank Russo)**

- a. Board renewal: Kathy Pichora-Fuller would be ending her tenure on the Board of Directors, after serving for four years, and would be replaced by a new member. Frank noted that the following year there would be several Board members stepping down including some officers. He called on Association members to consider joining the Board next year, pointing out that the aim is to achieve good representation of the various sectors composing the membership.
- b. Frank gave the floor to Tim Kelsall, who had been once more confirmed at the Board of Directors meeting as chair of the Standards Committee. Tim began with a brief historical account of the Standards group as the forebear of the Canadian Acoustical Association. He pointed out that the Committee deals with only one aggregate standard, being the combination of all pertinent international standards on noise and vibration, and referred participants to the CAA-ACA web site for information. He also noted that minutes of every meeting of the Committee are published in Canadian Acoustics and provide a convenient way for Association members to keep abreast of Canadian acoustical standards.
- c. Frank reminded participants of the importance of volunteers in the running of the Association, even in non-Board roles. Specifically, he noted that Sean Pecknold would be stepping down after long serving as webmaster and a volunteer was being sought to replace him, and that the new role of social media coordinator that Frank himself had filled initially would be shared by two volunteers, Huiwen Goy and Steven Sonnenberg.
- d. Turning to the business of the International Committee on Acoustics, Frank announced that Mike Stinson had been reconfirmed as Canadian representative on the ICA. He noted that the ICA can make a small budget available to national member organizations for the convening of special symposia, and reminded that following the 2016 meeting that was held in Buenos Aires, future meetings would take place in Aachen, Germany (2019) and Gyeongju, Korea (2022). He then gave the floor to Michael Stinson who said a few words about the proposal made to UNESCO to declare 2019 the International Year of Sound, patterned after the International Year of Light in 2015 which resulted in a major outreach.
- e. The floor was then given to Peter VanDelden, chair of the organizing committee for the 2017 CAA-ACA conference in Guelph, Ontario. Peter indicated that preparations were proceeding smoothly and noted that the meeting would coincide with the annual Oktoberfest celebration in Kitchener / Waterloo which might inspire a social theme for the event. He called on potential sponsors, exhibitors and session chairs to give the conference due consideration.
- f. Frank announced that the 2018 CAA-ACA conference would be held jointly with the autumn meeting of the ASA in Victoria, British Columbia. He noted that no financial commitment had been made by the Canadian association (thus no exposure to losses but no sharing in any potential profits). There would be technical coordination of sessions between the ASA and the CAA-ACA.

*MOTION to accept the President's report: moved by Tim Kelsall, seconded by Peter VanDelden, carried unanimously.*

#### **4. Treasurer's Report (Dalila Giusti)**

- a. Dalila gave a brief overview of the budget, explaining the distinctions and interrelation between Capital Fund, Operating Fund and Investments, and noted that the Association is in good financial shape.
- b. Investments last year yielded up to 40% return; this year a more modest 8% is expected.
- c. Dalila remarked that the organizers of this year's conference had used a different student subsidy paradigm from the traditional cash contribution toward travel fares, defraying hotel costs and registration fees instead. A sum of \$10,000 had been allocated in the Association's annual budget for the purpose of financing student travel subsidies; it remains unclear (until the conference accounting is finalized) how that will apply to the funding model used this year, but that budget allocation is approved for future conferences as well.

*MOTION to accept the Treasurer's report: moved by Stan Dosso, seconded by David Quirt, carried unanimously.*

#### **5. Secretary's Report (Roberto Racca)**

- a. Roberto gave a summary of the current participation levels in the Association, totalling 181 paid members and 26 sustaining subscribers. The overall membership level remains essentially unchanged from the same time in 2015, with a shift however to a greater proportion of student memberships (thus a net decrease in number of professional members). Roberto noted that the surge in student memberships likely resulted from the effective promotion by the conference organizers of travel subsidies for student members. The number of sustaining subscribers held steady.
- b. A few members have suggested that the Association consider instituting different types of membership, for example a lower-fee level for members who have retired from professional employment, or multi-year renewal options. Roberto indicated that the Board of Directors had been made aware of these suggestions and would be looking into viable approaches.
- c. On a related matter, some have commented on the inconsistent and seemingly interchangeable use of the terms "member" and "subscriber" especially in the wording of the on-line renewal forms. The common sense is that individuals take up (or renew) membership in the Association and receive a subscription to the journal as a benefit, but the on-line text appears to focus on the subscription as the key component. Roberto pointed out a related misperception that a sustaining subscription to the journal would lend membership status to the subscribing institution, whilst in fact membership in the Association is only open to individuals and must be taken up separately. He indicated that work was underway to revise any ambiguous wording in the informational materials and forms.
- d. Roberto encouraged members to communicate to him any concerns, suggestions or requests, as they would be given full consideration and would be brought up with the Board and/or executive of the Association for deliberation and action as needed.

*MOTION to accept the Secretary's report: moved by Peter VanDelden, seconded by Dalila Giusti, carried unanimously.*

#### **6. Editor's Report (J r mie Voix)**

- a. J r mie reported that at the Board of Directors meeting the budget had been approved for implementing Document Object Identifier (DOI) indexing of the journal content, both going forward and retroactively to all past issues. This move will enhance the external searching and referencing of articles in Canadian Acoustics.
- b. A potential publishing agreement with EBSCO has remained unresolved due to some underlying organizational issues; more recently the alternative has arisen of the publishing going to Springer. The matter is under consideration by the journal's advisory board and later will be reviewed by the Directors and possibly put to the membership.
- c. Several bugs were found in the database script used to generate the members' directory that appears annually in Canadian Acoustics, and shall be fixed for the upcoming directory in the December 2016 issue.
- d. J r mie reminded the members that they should ensure (through the on-line membership management form at [jcaa.caa-aca.ca](http://jcaa.caa-aca.ca)) that their full address information is included in the database, as missing fields can result in misprinting of shipping labels and consequent non-delivery of the Journal.
- e. A commercially issued SSL certificate for the CAA-ACA membership and conference registration sites will enhance their security validation.
- f. The impact index of Canadian Acoustics is under review; the rating from ESCI was disappointingly low in part because of a number of technical reasons that the Editor is presently assessing.
- g. J r mie invited Philippe Desjardins to say a few words about UNIWeb, a professional network of institutions and their academic researchers. This network has both a public side spanning all member institutes and a private side that is internal to an institute. The CAA-ACA already belongs to UNIWeb and its members can therefore join the network, but the dynamics of implementing the accounts are still under development.

- Kathy Pichora-Fuller raised the issue of how UNIWeb would serve the interests of non-scientist members of the Association, given the current academic slant of the network. On the other hand, she noted, it could become a bridge between the academic and the practitioner side of acoustics.
- h. Tim Kelsall asked about the possibility of changing the formatting of Canadian Acoustics articles to single column, which would be more reader friendly for reading PDF versions on-line. Jérémie responded that double column is still the standard format for most scientific journals, and the publishing industry places much emphasis on consistency. Vincent Mortimer suggested that a dual format for on-line delivery and print is now used by some publications.

## **7. Elections of the Board of Directors**

- a. Frank Russo gave a preamble outlining the procedure.
- The membership of the Association elects or ratifies Directors. Each director is only elected for a one-year term, so all Board members have to be re-elected (or replaced) at every AGM.
  - Officers are not elected, but appointed from and by the group of elected directors.
- b. Frank requested approval from the membership that a slate of twelve (12) directors be maintained. *Vote passed with none opposed.*
- c. Frank listed the proposed incumbent members of the slate: Alberto Behar (Ryerson University), Bill Gastmeier (HGC Engineering), Bryan Gick (University of British Columbia), Dalila Giusti (Jade Acoustics), Michael Kiefté (Dalhousie University), Hugues Nélisse (IRSST), Roberto Racca (JASCO Applied Sciences), Joana Rocha (University of Victoria), Frank Russo (Ryerson University), Mehrzad Salkhordeh (dB Noise Reduction), and Jérémie Voix (ETS). He announced that former director Kathy Pichora-Fuller would be stepping down, but Andy Metelka (SVS Canada) was willing to stand for the role.
- d. Members of the slate who were present at the meeting introduced themselves briefly, and Frank introduced the ones who were absent. Frank called for any questions from the floor to the members of the slate; none were asked.
- e. Frank asked whether there were any nominations from the floor, in which case an election would be held. Three calls for nominations were made with no response, so the slate was approved by acclamation.
- f. Kathy Pichora-Fuller was thanked for her many services to the Association.

*MOTION to adjourn: moved by Mehrzad Salkhordeh, seconded by Andy Metelka, carried.*

Meeting adjourned at 18:05.

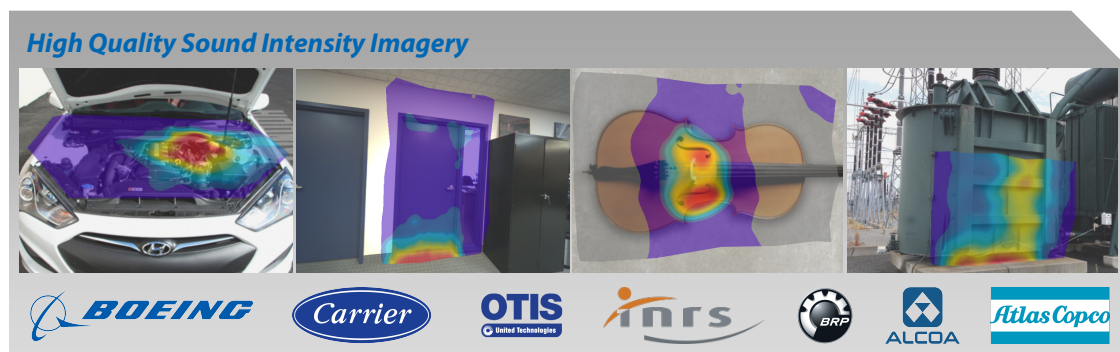
## MEZZO

Innovative and cost-effective acoustic solution

- Class 1 Sound Level Meter,
- Building Acoustics,
- Noise Monitoring,
- Sound Intensity,
- Sound Intensity Imagery.



Visit [www.SoftdB.com/mezzo](http://www.SoftdB.com/mezzo) for more info



**Soft dB**

1040, Belvedere Avenue, Suite 215,  
Quebec (Qc) G1S 3G3 Canada

Phone 1 (418) 686-0993  
Toll Free 1 (866) 686-0993

Web Site [www.softdb.com](http://www.softdb.com)  
E-mail [info@softdb.com](mailto:info@softdb.com)

**The Canadian Acoustical Association - L'Association canadienne d'acoustique**

**CANADIAN ACOUSTICS ANNOUNCEMENTS - ANNONCES  
TÉLÉGRAPHIQUES DE L'ACOUSTIQUE CANADIENNE**

**Tri-Agency Open Access Policy on Publications**

The good news? Publication and copyright policies of Canadian Acoustics journal are fully compliant with these new rules! That's another good reason for researchers to publish in Canadian Acoustics!

The Canadian Institutes of Health Research (CIHR), the Natural Sciences and Engineering Research Council of Canada (NSERC) and the Social Sciences and Humanities Research Council of Canada (SSHRC) are federal granting agencies that promote and support research, research training and innovation within Canada. As publicly funded organizations, the Agencies have a fundamental interest in promoting the availability of findings that result from the research they fund, including research publications and data, to the widest possible audience, and at the earliest possible opportunity. Societal advancement is made possible through widespread and barrier-free access to cutting-edge research and knowledge, enabling researchers, scholars, clinicians, policymakers, private sector and not-for-profit organizations and the public to use and build on this knowledge. - According to a new policy, all grant recipients that were funded in whole or in part by NSERC or SSHRC for grants awarded May 1, 2015 and onward (January 1, 2008 for CIHR) are required to ensure that any peer-reviewed journal publications arising from Agency-supported research are freely accessible within 12 months of publication.

*May 28th 2015*

**Looking for a job in Acoustics?**

There are many job offers listed on the website of the Canadian Acoustical Association!

You can see them online, under <http://www.caa-aca.ca/jobs/>

*August 5th 2015*

**CAA is now social!**

Canadian Acoustical Association is moving to the social media!

Find us on social media: - Twitter: CanAcoustical - Facebook: [facebook.com/canadianacousticalassociation](https://www.facebook.com/canadianacousticalassociation)

*December 14th 2015*

**Passing of Bill Lang**

We are saddened to inform you of the recent passing of Bill Lang

Bill Lang passed away on October 23, 2016. Bill held a special place in the International Noise Control Engineering (INCE) community. He was a founding member of I-INCE, former President and long-standing director. He was tireless and ever optimistic in his pursuit of Noise Control Engineering and shaping national and international policy. We thank Bill for his initiatives in pursuit of a quieter world.

*November 1st 2016*

### **Prof. Michael Kiefkte appointed as Associate Editor for Speech Sciences**

Prof. Michael Kiefkte, has recently accepted the position of Associate Editor for Speech Sciences for Canadian Acoustics.

Prof. Michael Kiefkte, has recently accepted the position of Associate Editor for Speech Sciences for Canadian Acoustics.

*November 5th 2016*

### **Philip Tsui appointed as webmaster for Canadian Acoustical Association**

Philip Tsui, has recently accepted to act as our new webmaster, and will be in charge of our core website, the journal website and the conference website. -

The Canadian Acoustical Association would like to thank again Dr. Sean Pecknold for all his service over the years.

*November 5th 2016*

### **Acoustics exhibition at the Musée de la Nature et des Sciences in Sherbrooke (QC)**

The Musée de la Nature et des Sciences in Sherbrooke will feature an exhibition on Acoustics.

A group from the Université de Sherbrooke led by Dr. Olivier Robin approached the CAA with a request for support of a new exhibition they are planning entitled 'Musée de la Nature et des Sciences'. This exhibit is intended to disseminate knowledge about acoustics to the general public, including information about sources of sound, sound propagation and sound reception. This initiative aligns well with our interest as an Association in education and outreach, as well as with activities being planned by the International Commission of Acoustics (of which the CAA is a member) for the proposed UNESCO "Year of sound" in 2019 (<http://www.sound2019.org>). The board agreed to commit up to \$2000 of financial support along with promotional assistance. We expect that the group will be able to present elements of the exhibition in the journal and at an upcoming Acoustics Week in Canada.

*November 5th 2016*

### **Politique des trois organismes sur le libre accès aux publications**

La bonne nouvelle ? Les termes de publication et de droit d'accès de la revue Acoustique canadienne sont parfaitement compatibles avec ces nouvelles mesures! Encore une autre bonne raison pour les chercheurs de publier dans Acoustique canadienne !

Les Instituts de recherche en santé du Canada (IRSC), le Conseil de recherches en sciences naturelles et en génie du Canada (CRSNG) et le Conseil de recherches en sciences humaines du Canada (CRSH), sont des organismes subventionnaires fédéraux qui favorisent et appuient la recherche, la formation en recherche et l'innovation au Canada. Comme les organismes sont financés par l'État, ils souhaitent, à la base, favoriser la diffusion le plus rapidement possible des résultats de la recherche qu'ils financent, notamment les publications et les données de recherche, auprès du plus grand nombre possible de personnes. On favorise les progrès sociaux en permettant aux chercheurs, aux universitaires, aux cliniciens, aux décideurs, aux organisations du secteur privé, aux organisations sans but lucratif et au grand public d'accéder librement et facilement aux connaissances et aux résultats de la recherche de pointe afin de les utiliser et de les mettre à profit. - Selon une nouvelle politique, tous les chercheurs qui détiennent une subvention du CRSNG et CRSH qui leur a été accordée avant le 1er mai 2015 (avant le 1er janvier 2008 pour les IRSC) doivent s'assurer que les articles découlant de la recherche financée par les organismes qu'ils publient dans une revue avec

comité de lecture sont accessibles gratuitement dans les 12 mois qui suivent leur publication.

May 28th 2015

### À la recherche d'un emploi en acoustique ?

De nombreuses offre d'emploi sont affichées sur le site de l'Association canadienne d'acoustique !

Vous pouvez les consulter en ligne à l'adresse <http://www.caa-aca.ca/jobs/>

August 5th 2015

**Scantek, Inc.** 

**Calibration Laboratory**

Scantek offers traceable, high quality and prompt periodic calibration of any brand of sound and vibration instrumentation

**Calibration and Service Capabilities:**

- Microphones
- Preamplifiers
- Acoustical Calibrators
- Sound Level Meters & Analyzers
- Accelerometers & Vibration Meters
- Vibration Calibrators and more

**ISO 17025:2005 and ANSI/NCSL Z-540-1: 1994 Accredited Calibration Laboratory**

**Scantek, Inc.** 

Sales, Rental, Calibration

[www.ScantekInc.com/calibration](http://www.ScantekInc.com/calibration) 800-224-3813

MEMBERSHIP DIRECTORY 2016 - ANNUAIRE DES MEMBRES 2016

**Adel A. Abdou**

King Fahd Univeristy of Petroleum and Minerals, (KFUPM)  
Architectural Engineering Dept. P.O. Box 1917  
Dharan 31261 - SA  
adel@kfupm.edu.sa  
+966 13 8602762

**Jennifer Abel**

University of British Columbia  
2613 West Mall, Vancouver, BC V6T 1Z4, - CA  
jennifer.abel@alumni.ubc.ca

**Forall Subscription Agency**

?

Av. Protasio Alves 1121 Loja 14, Porto Alegre  
RS 90410-001 - BR  
4ALL@FORALLBRASIL.COM.BR

**Dr. Steve James Aiken**

Dalhousie University  
1256 Barrington St, PO Box 15000, Halifax, NS,  
CANADA, B3J 4R2, - CA  
steve.aiken@dal.ca  
902-494-1057

**Brian Allen**

?

130B Pippin Road, , Vaughan, ON, L4K 4X9  
CA, - CA  
BAllen@ehpricesales.com

**Mr. David John Aquilina**

Kinetics Noise Control, Inc.  
33 Concord Ave, Dundas, On, L9H 1R8, - CA  
daveaquilina@gmail.com  
416-779-1526

**G. Robert Arrabito**

?

1133 Sheppard Ave. West, M3K 2C9 , - CA  
robert.arrabito@drdc-rddc.gc.ca

**Jessica Arsenaault**

Rotman Research Institute, University of  
Toronto  
Baycrest Hospital, 3560 Bathurst St, Toronto,  
ON, M6A 2E1, - CA  
jess.arsenaault@mail.utoronto.ca

**ASHA Learning Res. Center**

?

A T Still Univ Hlth Sci, 5850 E Still Circ, Mesa,  
AZ 85206 - US  
indirectusa3@caa-aca.ca

**Marc Asselineau**

?

10 B rue des Messageries Paris, F75010 - FR  
m.asselineau@peutz.fr  
33-1-45230500

**James Au**

AECOM Canada Ltd., 5080 Commerce  
Boulevard, Mississauga, Ontario, Canada,  
L4W4P2  
18 Lockdare St. M1S 2Z6 - CA  
jamesau1@gmail.com  
905-712-7056

**Mr. Frank Babic**

AMEC  
160 Traders Blvd. E., Suite 110 Mississauga,  
ON L4Z 3K7 - CA  
frank.babic@amec.com  
905.568.2929

**Walid Baccari**

?

Québec-Océan, Pavillon  
Alexandre-Vachon1045, Avenue de la  
Médecine, local 2064, Université Laval,  
Québec (Québec), G1V 0A6, Canada, , - CA  
walid.baccari.1@ulaval.ca  
418 931-8303

**Jeffery S. Bamford**

Engineering Harmonics Inc  
1249 McCraney Street East L6H 3A3 - CA  
jBamford@EngineeringHarmonics.com  
4164653378

**Mr. Alberto Behar**

Ryerson University  
307 - 355 St Clair W, Toronto, M5P 1T5 - CA  
albehar31@gmail.com  
(416) 265-1816

**Simon Benacchio**

École de technologie supérieure, Institut de  
recherche Robert-Sauvé en Santé et en Sécurité  
du Travail  
ÉTS, Génie Mécanique, 1100 Notre-Dame  
Ouest, Montreal (QC) H3C1K3 - CA  
simon.benacchio@irsst.qc.ca  
438-928-2559

**M Abdelghani Benghanem**

Université de Sherbrooke  
1473 Rue Leonard, J1K 2L9 Sherbrooke,  
Quebec, - CA  
abdelghani.benghanem@usherbrooke.ca  
819-919-2343

**Dr. Umberto Berardi**

Ryerson University  
350 Victoria Street,, Ryerson University, Dep  
Architectural Science,, Toronto, Ontario, M5B  
2K3, - CA  
uberardi@ryerson.ca  
416 979 5000 (3263)

**Mr. Elliott H. Berger**

3M Personal Safety Division  
7911 Zionsville Rd 46268 - US  
elliott.berger@mmm.com

**Lucie Beriault**

?

Centre de documentation, 1255, rue  
Beauregard, Longueuil, J4K 2M3 - CA  
lucie.beriault.agence16@ssss.gouv.qc.ca

**Dylan Bernhard**

University of Alberta  
? - CA  
dbernhar@ualberta.ca

**M Serge Berube**

?

1625, route Marie-Victorin J3R 1M6 - CA  
serge.berube@riotinto.com  
450-746-3118

**Ryan Bessey**

?

25 Telegram Mews, Suite 2907, M5V 3Z1 , - CA  
ryan.bessey@hotmail.com

**Mr Stéphane Beuvelet**

Université de Sherbrooke  
2, 993 rue belvédère Sud, J1H4S9 Sherbrooke,  
Quebec, - CA  
s.beuvelet@gmail.com  
1 819 588 6584

**Chris Bibby**

?

4208 7th ave SW, Calgary, T3C0E4, - CA  
chrisbibby@gmail.com

**Meghan Billingsley**

ROXUL  
1464 Cornwall Road, Suite 11 Oakville, ON  
L6J 7W5 - CA  
amanda@birchallpr.com  
9053387600

**Dr. Heather Bliss**

?

21 - 4080 Garry Street, Richmond BC  
CANADA, V7E6J9, - CA  
hbliss@uvic.ca

**Atif Bokhari**

?

7101 Branigan Gate, #17, L5N 7S2 - CA  
atif.bokhari@aecom.com

**Tanor Bonin**

University of Waterloo  
? - ?  
tanorbonin@gmail.com

**Fabien Bonnet**

École de Technologie Supérieure  
1175-7 Boulevard de Maisonneuve Est,  
Montréal H2L 1Z8, - CA  
fabien.bonnet.1@ens.etsmtl.ca  
5144047900

**Ian Bonsma**  
HGC Engineering  
2000 Argentina Road, Plaza 1, Suite 203 L5N  
1P7 - CA  
ibonsma@hgcengineering.com  
905-826-4044

**Forest Borch**  
?  
? - CA  
borch@bkl.ca

**Kyra Ann Borland-Walker**  
University of Victoria  
406-21 Gorge Road East, Victoria BC, Canada,  
V9A 0G2, - CA  
kyrabw93@gmail.com  
7789905972

**Sylvain Boyer**  
?  
D, 1100 rue Notre-Dame Ouest, Montr, H3C  
1K3, - CA  
sylvain.w.o.boyer@gmail.com

**Dr. A.J. Brammer**  
Envir-O-Health Solutions  
4792 Massey Lane, K1J 8W9 - CA  
anthonybrammer@hotmail.com  
613 744 5376

**Daniel Brenner**  
University of Alberta  
19-10646 / 85 Ave NW, Edmonton AB, T6E  
2K7, - CA  
brenner@ualberta.ca

**British Library**  
British Library  
Acquisitions Unit (DSC-AO), Boston Spa,  
Wetherby, LS23 7BQ - GB  
indirectintl@caa-aca.ca

**David W. Brown**  
?  
Brown Strachan Assoc., Two Yaletown Sq.,  
1290 Homer St., Vancouver, BC, V6B 2Y5 - CA  
bsa@brownstrachan.com

**Martin Brummund**  
?  
425 De La Montagne, App. 4114, Montréal,  
QC, H3C 0J9, - CA  
martin.brummund.1@ens.etsmtl.ca

**Ellen Buchan**  
?  
Alberta Infrastructure, Technical Services  
Branch, 3rd Floor, 6950-113 St, Edmonton, AB,  
T6H 5V7 - CA  
ellen.buchan@gov.ab.ca

**Claudio Bulfone**  
?  
531 - 55A St. Delta, BC V4M 3M2 - CA  
cbulfone@gmail.com

**Brian Bulnes**  
AECOM  
? - CA  
brian.bulnes@aecom.com  
905-712-7057

**Mr. Todd Anthony Busch**  
Todd Busch Consulting  
Todd Busch Consulting, #803 - 615 Belmont St,  
New Westminster, B.C. V3M6A1, - CA  
toddbusch@hotmail.com  
6045224567

**Wil Byrick**  
?  
1370 Don Mills Rd, Unit 300 Toronto, ON M3B  
3N7 - CA  
wbyrick@pliteq.com  
416-449-0049

**Kevin Carr**  
?  
Environmental Noise Architectural Acoustics,  
300 Auden Road, Guelph, ON, N1E 6S3, - CA  
kevincarr@gmail.com

**Mandy Chan**  
?  
HGC Engineering, 2000 Argentinia Road, Plaza  
1, Suite 203, Mississauga, ON, L5N 1P7, - CA  
machan@hgcengineering.com

**N. Ross Chapman**  
?  
University of Victoria, School of Earth &  
Ocean Sciences, P.O. Box 3055, Victoria, BC,  
V8W 3P6, - CA  
chapman@uvic.ca

**Brian Chapnik**  
?  
HGC Engineering Ltd., 2000 Argentinia Rd.,  
Plaza One, Suite 203, Mississauga, ON, L5N  
1P7 - CA  
bchapnik@hgcengineering.com

**Marshall Chasin**  
?  
34 Bankstock Dr., North York, ON, M2K 2H6,  
- CA  
marshall.chasin@rogers.com

**M. Cheesman**  
?  
University of Western Ontario Dept.  
Communication Sciences & Disorders  
Faculty of Health Sciences, Elborn College  
London, ON N6G 1H1 - CA  
cheesman@uwo.ca

**Ping Chen**  
?  
840 Everett Crescent, Burnaby, BC, V5A 2N4,  
- CA  
ping\_calgary@yahoo.com

**Mark Cheng**  
?  
Vancouver Airport Authority, PO Box 23750,  
Airport Postal Outlet, Richmond, BC, V7B 1Y7  
- CA  
mark\_cheng@yvr.ca

**Lauretta Sze Pui Cheng**  
University of British Columbia  
8-5688 Dalhousie Road, Vancouver, BC  
V6T1W4, - CA  
lauretta.cheng@alumni.ubc.ca

**Chinese Academy of Sciences Library**  
?  
PO Box 830470, Birmingham, AL, 35283 - US  
indirectUSA1@caa-aca.ca

**Chenhao Chiu**  
?  
Totem Field Studio 2613 West Mall Vancouver,  
BC - CA  
chenhao@alumni.ubc.ca

**Ms Ina Chomyshyn**  
True Grit Consulting Ltd  
1263 Innovation Drive, Thunder Bay, Ontario,  
P7B 0A2, - CA  
ina@tgcl.ca  
807-626-5640

**Wladyslaw Cichocki**  
University of New Brunswick  
University of New Brunswick, Dept of French,  
Fredericton, NB E3B 5A3, - CA  
cicho@unb.ca  
506-447-3236

**Greg Clunis**  
?  
907 Admiral Ave., Ottawa, ON, K1Z 6L6 - CA  
greg@integraldxengineering.ca  
613-761-1565

**James P. Cottingham**  
?  
Physics Department, Coe College, 1220 First  
Avenue NE, Cedar Rapids, IA, 52402, - USA  
jcotting@coe.edu

**Ann Cox**  
ARCADIS SENES Canada Inc.  
121 Granton Drive, Unit 12 Richmond Hill,  
ON L4B 3N4 - CA  
acox@senes.ca

**Dr Briony Elizabeth Croft**  
SLR Consulting (Canada)  
Suite 200 - 1620 West 8th Avenue, Vancouver,  
BC, V6J 1V4, Canada, - ?  
bcroft@slrconsulting.com  
6047904202

**CSIC - Biblioteca**  
?  
Ctro Tecnol Físicas L Torres Quevedo, Serrano  
144, 28006 MADRID - ES  
Alex.Clemente@Lminfo.es

**Dr Gilles Daigle**  
?  
National Research Council, Building U66,  
Ottawa, ON K1A 0R6 - CA  
gilles.daigle@nrc.gc.ca  
819-561-7857

**Tom Dakin**  
Ocean Networks Canada  
2098 Skylark Lane Sydney, BC V8L 1Y4 - CA  
TDakin@UVic.ca  
250-853-3541

**Shira Daltrop**

?  
#301-1950 W8th Ave - CA  
shira\_d47@hotmail.com  
6047651663

**Steve Davidson**

Davidson & Associés Inc.  
12 Lafleur St. N , St-Sauveur, QC , J0R 1R0 - CA  
sdavidson@davidson-assoc.com

**Jack Davis**

?  
6331 Travois Cres NW, Calgary, AB, T2K 3S8, - CA  
davisjd@telus.net  
403-275-6868

**Henk de Haan**

dBA Noise Consultants  
dBA Noise Consultants RR1, Site 14, Box 55  
Okotoks, AB T1S 1A1 - CA  
dBAnoiseconsultants@gmail.com  
403 836 8806

**Lucas Demysh**

?  
Metallurgical Sensors Inc., 630-420 Main Street  
East, Milton, ON, L9T 5G3, , - CA  
ldemysh@metsen.com  
905-876-0966

**Mr. Terry J. Deveau**

Jasco Applied Sciences  
3 Shore Road Herring Cove, NS B3V 1G6 - CA  
deveau@chebucto.ns.ca  
902-479-3398

**Ric Doedens**

K R Moeller Associates Ltd.  
3-1050 Pachino Court, Burlington, Ontario,  
L7L 6B9 - CA  
rdoedens@logison.com  
905-332-1730

**Justin DosRamos**

?  
2031 3 Avenue N.W., Calgary, AB, T2N 0K3, - CA  
jdosramos@ffaacoustics.com

**Stan Dosso**

University of Victoria  
University of Victoria, School of Earth and  
Ocean Sciences, P.O. Box 3055, Victoria, BC,  
V8W 3P6 - CA  
sdosso@uvic.ca

**Olivier Doutres**

École de technologie supérieure (ÉTS)  
École de technologie supérieure, 1100 Rue  
Notre-Dame Ouest, Montréal, QC H3C 1K3, - CA  
olivier.doutres@etsmtl.ca

**Teresa Drew**

?  
#1000 736 8th Ave SW, , Calgary, AB, T2P 1H4  
CA, - CA  
teresa.drew@rwdi.com

**Mr. Robert William Drinnan**

University of British Columbia  
2284 Cooperidge Drive, Saanichton BC,  
V8M1N2, - CA  
robert.drinnan@gmail.com

**Alex Dundon**

AECOM  
5600 Cancross Court, Suite A, Mississauga,  
Ontario L5R 3E9 - CA  
alex.dundon@aecom.com

**David Egan**

Egan Acoustics  
P.O. Box 365, Anderson, SC, 29622-0365, - US  
eegan@g.clemson.edu  
864-226-3832

**Dale D. Ellis**

?  
18 Hugh Allen Drive, Dartmouth, NS B2W  
2K8 - CA  
daledellis@gmail.com  
902-464-9616

**Prof. John H Esling**

University of Victoria  
Department of Linguistics, University of  
Victoria, Victoria, BC V8W 3P4, - CA  
esling@uvic.ca  
2504772270

**Pascal Everton**

SLR Consulting (Canada) Ltd.  
#1185, 10201 Southport Road S.W. Calgary, AB  
T2W 4X9 - CA  
peverton@slrconsulting.com

**James Farquharson**

?  
FDI Acoustics, Suite 250, 600 Crowfoot  
Crescent NW, Calgary, AB, T3G 0B4 - CA  
james@fdiacoustics.com

**Andrew Faszer**

?  
Golder Associates Ltd., 102, 2535 - 3rd Avenue  
S.E., Calgary, Alberta, Canada T2A 7W5 - CA  
andrew.faszer@ualberta.net  
403-698-4554

**Clifford Faszer**

?  
FFA Consultants in Acoustics & Noise  
Control Suite 210 3015 - 5th Avenue N.E.  
Calgary, AB T2A 6T8 - CA  
cfaszer@ffaacoustics.com

**Clifford Faszer**

?  
Suite 210N, 3015-5th Ave NE Calgary, AB T2A  
6T8 T2A 6T8 - CA  
info@ffaacoustics.com  
403.508.4996

**Harold Forester**

?  
1434 Franklin, Laval, QC H7W 1K6 - CA  
hforester@outlook.com  
450-681-2333

**Leslie D Frank**

SLR Consulting (Canada) Ltd.  
SLR Consulting (Canada) Ltd.. 1185, 10201  
Southport Rd. SW Calgary, AB T2W 4X9 - CA  
LFrank@SLRconsulting.com  
403-385-1306

**Atsushi Fujimori**

Shizuoka University, JAPAN  
Faculty of Informatics, Shizuoka University,  
3-5-1 Johoku Naka-ku Hamamatsu, 432-8561,  
JAPAN, - JP  
fujimori.atsushi@shizuoka.ac.jp  
+81-53-478-1523

**Mr. Robert Fuller**

Safetech Environmental Ltd.  
3045 Southcreek Road, Unit 14, Mississauga,  
Ontario, L4X 2X7, - CA  
rfuller@safetechenv.com

**W. Robert J. Funnell**

?  
McGill University, Biomedical Engineering &  
Otolaryngology, 3775, rue University,  
Montréal, QC, H3A 2B4 , - CA  
robert.funnell@mcgill.ca

**Mr. Vince Gambino**

Vintec Acoustics  
Vintec Acoustics, 6-2400 Dundas Street West,  
Mississauga, Ontario, L5K 2R8, - CA  
vgambino@vintecacoustics.com  
416-455-5265

**Bill Gastmeier**

HGC Engineering  
12 Roslin Ave S., Waterloo, ON, N2L 2G5 - CA  
gastmeier@rogers.com

**Dr Marc-André Gaudreau**

Cégep de Drummondville  
38 Descoteaux, Drummondville, Québec, J1Z  
2L2, - CA  
marc-andre.gaudreau@cegepdrummond.ca  
819-388-3714

**Mohammad Sadegh GHOLAMI**

Université de Sherbrooke  
1695,rue Marcil, Sherbrooke QC, , J1J 2H7, - CA  
mohammad.sadegh.gholami@usherbrooke.ca  
8195803838

**Mr. Hazem Gidamy**

M.Eng. P.Eng.  
SS Wilson Associates Acoustical Consulting  
Engineers 15 Wertheim Court, Suite 211  
Richmond Hill, ON L4B 3H7 - CA  
info@sswilsonassociates.com  
905-707-5800

**Prof. Christian Giguère**

University of Ottawa  
Audiology/SLP Program, 451 Smyth Road,  
Ottawa, Ontario, K1H8M5, - CA  
cgiguere@uottawa.ca  
(613) 562-5800 x4649

**Ms. Dalila Giusti**  
Jade Acoustics Inc.  
411 Confederation Parkway Unit 19 Concord  
Ontario L4K 0A8 - CA  
dalila@jadeacoustics.com  
905-660-2444

**Huiwen Goy**  
Ryerson University  
Ryerson University, Department of  
Psychology, 350 Victoria St, Toronto, ON M5B  
2K3, - CA  
huiwen.goy@utoronto.ca

**Dr. Anant Grewal**  
National Research Council  
National Research Council, 1200 Montreal  
Road, Ottawa, Ontario, K1A-0R6, - CA  
anant.grewal@nrc-cnrc.gc.ca  
(613) 991-5465

**Mr. Manfred Grote**  
ARCOS Acoustical Consulting  
2828 Toronto Cres. N.W. Calgary, AB T2N  
3W2 - CA  
arcosacoustic@shaw.ca  
403-283-1191

**Monsieur Nassardin Nassar Guenfoud**  
Université de Sherbrooke  
1530 Rue Cabana, J1K 2N3, - CA  
nassardin.guenfoud@gmail.com

**Peter Hanes**  
?  
National Research Council Bldg M-36 Ottawa,  
ON K1A 0R6 - CA  
ph3238@yahoo.ca

**David Hannay**  
?  
JASCO Research Ltd., 2305 - 4464 Markham  
Street, Victoria, BC, V8Z 7X8, - CA  
dave@jasco.com

**Harriet Irving Library**  
?  
University of New Brunswick, PO Box 7500,  
Fredericton, NB, E3B 5H5 - CA  
indirectcan3@caa-aca.ca

**Md Mehadi Hasan**  
University of British Columbia  
? - CA  
mehadi06buet@gmail.com

**Gillian Hatcher**  
Stantec Consulting Ltd  
40 Highfield Park Drive,, Dartmouth, NS, B3A  
0A3, - CA  
gillian.hatcher@stantec.com  
902-468-7777

**Kyle Hellewell**  
?  
RWDI Air, 650 Woodlawn Rd West, Guelph,  
ON, N1K 1B8, - CA  
kyle.hellewell@rwdi.com

**Robert Hellweg**  
?  
13 Pine Tree Road, Wellesley, MA, 02482-4503,  
- USA  
Hellweg@HellwegAcoustics.com

**Matt Hildebrand**  
Wenger Corporation  
Wenger Corporation 555 Park Drive PO Box  
448 Owatonna, MN 55060 - US  
matt.hildebrand@wengercorp.com  
507-774-8716

**Dr. Murray Hodgson**  
?  
University of British Columbia, School of Env.  
Health, 2206 East Mall, 3rd Fl., Vancouver, BC,  
V6T 1Z3, - CA  
murray.hodgson@ubc.ca

**Dr. Christoph Hoeller**  
National Research Council Canada  
1200 Montreal Road, Building M-27, Ottawa,  
Ontario, K1A 0R6 - CA  
christoph.hoeller@nrc.ca

**Joe Hood**  
Akoostix Inc.  
Akoostix Inc. Suite 12, 10 Akerley Blvd  
Dartmouth, NS B3B 1J4 - CA  
jhood@akoostix.com  
(902) 404-7464

**Monsieur Mathieu Hotton**  
Université Laval  
1775 rue du Fleuret, L'Ancienne-Lorette, QC, -  
CA  
mathieu.hotton.1@ulaval.ca  
4189779754

**Brian Howe**  
Howe Gastmeier Chapnik Limited  
HGC Engineering, Plaza One, Suite 203 2000  
Argentia Rd. Mississauga, ON L5N 1P7 - CA  
bhowe@hgcengineering.com  
9058264044

**Lin Hu**  
?  
FPInnovations, 319, rue Franquet, Québec,  
QC, G1P 4R4, - CA  
lin.hu@fpinnovations.ca

**Dr. Amir Iravani**  
Dillon Consulting Limited  
53 Banstock Drive Toronto ON M2K 2H7 - CA  
airavani@dillon.ca

**John Hopkins University**  
?  
Serials / Acquisitions - 001ACF5829EI, Milton  
S. Eisenhower LibraryBaltimore, MD, 21218 -  
US  
indirectusa2@caa-aca.ca

**Prof. Jeffery A. Jones**  
Wilfrid Laurier University  
? - CA  
jjones@wlu.ca

**Dr Stephen E. Keith**  
Health Canada  
Radiation Protection Bureau, Health  
Acoustics, Non-ionizing Radiation Section Rm  
228, 775 Brookfield Rd., 6301B Ottawa, ON  
K1A 1C1 - CA  
stephen\_keith@hc-sc.gc.ca  
+1 613 941-8942

**Tim Kelsall**  
Hatch  
2800 Speakman Dr. , Mississauga, ON, L5K  
2R7 - CA  
tkelsall@hatch.ca  
905-403-3932

**Douglas S. Kennedy**  
?  
BKL Consultants Ltd., #308-1200 Lynn Valley  
Rd, North Vancouver, BC, V7J 2A2 - CA  
kennedy@bkl.ca

**Ms. Kathryn Joanne Kennedy Katsiroumpas**  
None  
17 Linnsmore Crescent, Toronto, Ontario, M4J  
4J8, - CA  
kkatsiroumpas@hotmail.com  
4164660625

**Megan Keough**  
University of British Columbia  
2613 West Mall, Vancouver, BC V6T 1Z4 - CA  
mkeough@alumni.ubc.ca

**Andrew Khoury**  
?  
6600 Trans Highway, Suite 511, Pointe-Claire,  
QC, H9R 4S2 - CA  
andrew.khoury@bksv.com  
514-695-8225

**Mr. Corey Kinart**  
HGC Engineering  
2000 Argentia Road, Plaza One, Suite 203,  
Mississauga, Ontario, L5N 1P7, - CA  
ckinart@hgcengineering.com  
905-826-4044

**Mr. Ivan Koval**  
Reliable Connections Inc.  
? - CA  
soundproofing.expert@gmail.com  
416-471-2130

**Kelly Kruger**  
?  
5407 109A Ave NW, Edmonton, AB, T6A 1S6,  
- CA  
kkruger@telus.net

**André L'Espérance**  
?  
1040, avenue Belvédère, suite 215, Sillery, QC,  
G1S 3G3 - CA  
info@softdb.com  
418-686-0993

**Alice Lam**  
?  
? - ?  
avl@alumni.ubc.ca

**Jean Laporte**

ACOUSTIKALAB INC.  
CP 52523, 324 rue Castelneau,, Montréal,  
Québec,, H2R 3C5, - CA  
jlaporte@acoustikalab.com  
514-692-1147

**Dr. Chantal Laroche**

?

Programme d'audiologie et d'orthophonie  
École des Sciences de la réadaptation Faculté  
des Sciences de la santé Université d'Ottawa  
451 Chemin Smyth Ottawa, ON K1H 8M5 - CA  
claroche@uottawa.ca  
613-562-5800 3066

**Monsieur Daniel Larose**

Dalimar Instruments ULC  
193 Joseph Carrier Vaudreuil-Dorion, QC J7V  
5V5 - CA  
daniel@dalimar.ca  
450-424-0033

**Sin-Tung Lau**

Wilfrid Laurier University, Toronto  
Rehabilitation Institute  
? - ?  
laux4100@mylaurier.ca

**Frédéric Laville**

École de technologie supérieure  
Ecole de technologie supérieure Université du  
Québec 1100 Notre-Dame Ouest Montréal, QC  
H3C 1K3 - CA  
frederic.laville@etsmtl.ca

**Cécile Le Cocq**

École de technologie supérieure  
1100 rue Notre-Dame Ouest, Montréal (QC)  
H3C 1K3 - CA  
copyeditor@caa-aca.ca

**Buddy Ledger**

?

5248 Cedar Springs Road, Burlington, Ontario  
L7P 0B9, - CA  
buddyledger@gmail.com

**Richard Levesque**

HTS Engineering  
1646 Woodward Drive, Ottawa, Ontario, K2C  
3R8, - CA  
richard.levesque@hts.com  
613-728-7400

**Marcus Li**

?

177 Westfield Trail, Oakville, ON, L6H 6H7, -  
CA  
Li.MarcusTW@gmail.com

**Zhao Li**

Harbin Engineering University, University of  
Victoria  
4210 Tyndall Ave. Victoria, BC - CA  
lizhao0517@gmail.com

**Elaine Lightstone**

?

30 Wertheim Court, Unit 25, Richmond Hill,  
ON, L4B 1B9 - CA  
elaine@valcoustics.com  
905-764-5223

**Chang Liu**

Editorial Development Dept., Thomson  
Reuters  
? - ?  
chang.liu@thomsonreuters.com

**Alexander P. Lorimer**

?

HGC Engineering Ltd., Plaza One, Suite 203,  
2000 Argentia Rd., Mississauga, ON, L5N 1P7  
, - CA  
alorimer@hgcengineering.com

**Parnia Lotfi Moghaddam**

MMM Group Limited  
100 Commerce Valley Drive West Thornhill,  
ON L3T 0A1 - CA  
lotfimoghaddamp@mmm.ca  
905-882-4211 ext. 6577

**Roderick Mackenzie**

SoftdB  
1240 Beaumont Avenue, Suite 206, Montreal,  
QC, H3P 3E5 - CA  
r.mackenzie@softdb.com

**Ewan Andrew Macpherson**

Western University  
Western University, 1201 Western Rd, Elborn  
College Room 2262, London, ON N6G 1H1, -  
CA  
ewan.macpherson@nca.uwo.ca  
519-661-2111 x88072

**Dr. Gary S. Madaras**

Rockfon  
4849 S. Austin Ave., Chicago, IL 60638 - US  
gary.madaras@rockfon.com  
708.563.4548

**Md Amin Mahmud**

"University of British Columbia"  
3rd Floor, 2206 East Mall, Vancouver, BC,  
Canada V6T 1Z3 - CA  
amahmud@alumni.ubc.ca  
778-681-2348

**Miss Joyce Mak**

British Columbia Institute of Technology,  
University of Waterloo, BCBE, APEGBC  
9607A Roosevelt Way NE, Seattle, WA, 98115 -  
US  
jmak.joyce@gmail.com

**Gary Mak**

BKL Consultants Ltd.  
308 1200 Lynn Valley Road, North Vancouver,  
BC, Canada, V7J 2A2, - CA  
mak@bkl.ca  
604-988-2508

**Denise Mallette**

IRSST  
I.R.S.S.T. - Informatique 11e étage 505 boul  
de Maisonneuve O Montréal, QC H3A 3C2 -  
CA  
mallette.denise@irsst.qc.ca  
514-288-1551

**Mr Paul E Marks**

BKL Consultants Ltd  
BKL Consultants Ltd, #308 - 1200 Lynn Valley  
Road, North Vancouver, BC, Canada, V7J 2A2  
- CA  
marks@bkl.ca  
604-988-2508

**Emma Marotte**

Dalhousie University  
2498 Robie Street, Halifax, NS, B3K4N1, - CA  
emma.marotte@gmail.com

**Duane Marriner**

?

301-2250 Oak Bay Avenue, Victoria, BC V8R  
1G5, - CA  
duane.marriner@rwdi.com

**Steve Marshall**

Scantek, Inc.  
Scantek, Inc., 6430 Dobbin Road, Suite C,  
Columbia, MD 21045, - US  
S.Marshall@scantekinc.com  
1-410-290-7726

**Christian Martel**

?

Octave Acoustique Inc., 963, chemin Royal,  
Saint-Laurent-de-l'Île-d'Orleans, QC, G0A  
3Z0 - CA  
octave@videotron.ca

**Alexis Martin**

Ecole de Technologie Supérieure  
? - ?  
alexis.martin.1@ens.etsmtl.ca

**John Martyn**

?

Right to Quiet Society, 359 - 1985 Wallace  
Street, Vancouver, BC, V6R 4H4 - CA  
info@quiet.org

**Michael Masschaele**

GHD  
651 Colby Drive Waterloo, Ontario N2V 1C2 -  
CA  
michael.masschaele@ghd.com

**Patrice Masson**

Universite de Sherbrooke  
Département de génie mécanique, Université  
de Sherbrooke, 2500, boul. Université,  
Sherbrooke, QC, J1K 2R1, - CA  
patrice.masson@usherbrooke.ca  
819-821-8000 x62152

**Eric Matheson-Jones**

?

9628 Austin O'Brien Road NW Edmonton, AB  
T6B 2C2 - CA  
mathesonjones@gmail.com

**Mr Nigel Maybee**

SLR Consulting (Canada) Ltd.  
SLR Consulting (Canada) Ltd., #1185-10201  
Southport Road SW, Calgary, AB, T2W 4X9 -  
CA  
nmaybee@slrconsulting.com  
403-385-1308

**Connor Mayer**

?  
#540- 2050 Scotia St., Vancouver, BC, V5T 4T1,  
- CA  
connor.joseph.mayer@gmail.com

**Nick McCabe**

?  
HGC Engineering, 2000 Argentia Road Plaza 1  
Suite 2003, Mississauga, ON, L5N 1P7 - CA  
nmccabe@hgceengineering.com

**Stephen McCann**

Cambium Inc.  
597 Homewood Avenue, Peterborough,  
Ontario K9H2N4 - CA  
stephen.mccann@cambium-inc.com

**MDDEP**

?  
Dir politique de la qualité de l'atmosphère,  
675 Rene-Levesque Est 5E-B30, Québec, QC,  
G1R 5V7 - CA  
indirectcan4@caa-aca.ca

**Mr. T. Medwedyk**

?  
Group One Acoustics Inc., 1538 Sherway Dr.,  
Mississauga, ON, L4X 1C4 - CA  
goainc@bellnet.ca

**M. Jason MEJANE | Université de  
Sherbrooke | Centre de technologies  
avancées BRP - Université de Sherbrooke  
(CTA)3000 boulevard de l'Université | Bât.  
P1 | Sherbrooke | Québec**

Canada  
J1K 0A5 - CA  
jason.mejane@usherbrooke.ca

**Garfield Mellema**

Defence Research & Development Canada -  
Atlantic  
Defence Research Establishment Atlantic P.O.  
Box 1012 Dartmouth, NS B2Y 3Z7 - CA  
garfield.mellema@drdc-rddc.gc.ca

**Steve Meszaros**

?  
4567 Valley Road, North Vancouver, BC, V7K  
2M1, - CA  
steve\_meszaros@hotmail.com

**J.G. Migneron**

Acoustec Inc.  
90, rue H.-Poirier, , Lévis, QC , G7A 2W1 - CA  
courrier@acoustec.qc.ca  
418-496-6600

**M. Jean-Philippe Migneron**

Université Laval  
1393-204, rue de Jupiter, Lévis, QC G6W 8J3 -  
CA  
jean-philippe.migneron.1@ulaval.ca  
418-906-0333

**Peter Milne**

McGill University  
182C Sherway Dr, Nepean, ON, K2J 2G8, - CA  
pmln099@gmail.com

**Rachel Min**

Vancouver Airport Authority  
PO Box 23750 Airport Postal Outlet,  
Richmond, BC V7B 1Y7 - CA  
rachel\_min@yvr.ca

**Takashi Mitsuya**

University of Western Ontario  
National Centre for  
Audiology Communication Sciences and  
Disorders Elborn College, Room 1207,  
University of Western  
Ontario London, Ontario, Canada N6G 1H1 -  
CA  
tmitsuya@uwo.ca

**Philippe Moquin**

Alberta Infrastructure  
Technical Services Branch 3rd Floor,  
Infrastructure Building 6950 -113 Street NW  
Edmonton, AB, T6H 5V7 - CA  
philippe.moquin@gov.ab.ca  
7804272784

**Joaquin E. Moran**

?  
Hatch Ltd., 4342 Queen St., Suite 500, Niagara  
Falls, ON, L2E 7J7 - CA  
jmoran@hatch.ca

**Michel Morin**

?  
6555 Cote des Neiges, Suite 440 Montréal, QC  
H3S 2A6 - CA  
mmorin@mjm.qc.ca  
514-737-9811

**Dr Geoffrey Stewart Morrison**

University of Alberta, University of New  
South Wales  
803-4438 West 10th Avenue, Vancouver BC  
V6R 4R8 - CA  
geoff-morrison@forensic-evaluation.net  
604 637 0896

**Rasoul Morteza Pouraghdam**

MASc in Mechanical Engineering,  
Specialization Acoustics, Concordia  
University, Montreal  
? - CA  
r\_morte@encs.concordia.ca

**Xavier Mouy**

JASCO Applied Sciences  
? - ?  
xavier.mouy@jasco.com

**Yoichi Mukai**

University of Alberta  
Department of Linguistics, 3-26 Assiniboia  
Hall, University of Alberta, Edmonton AB  
Canada T6G - ?  
mukai@ualberta.ca  
(780) 710-7516

**M. Vincent Nadon**

École de technologie supérieure, , Gent  
University  
316 Major Lavallée,, Deux-Montagnes, Qc,,  
Canada, J7R 6M8, - CA  
vincent.nadon@etsmtl.ca

**Ann Nakashima**

?  
DRDC Toronto, 1133 Sheppard Ave. W.,  
Toronto, ON, M3K2C9 - CA  
ann.nakashima@drdc-rddc.gc.ca

**Flora Nassrallah**

University of Ottawa  
6072 Red Willow Drive, Ottawa, Ontario,  
K1C7J5 - CA  
fnass039@uottawa.ca

**Hugues Nelisse**

?  
IRSST 505 Boul de Maissonneuve Ouest  
Montréal, QC H3A 3C2 - CA  
nelisse.hugues@irsst.qc.ca

**Gabe Nespoli**

Ryerson University  
105 Bond St, SBB-262, Toronto, ON M5B 1Y3,  
CANADA, - CA  
gabe@psych.ryerson.ca

**Mr. Phat Nguyen**

?  
Produits Acoustiques PN Inc., 2875 RUE  
JASMIN, Saint-Laurent, QC, H4R 1H8, - CA  
pn@acoustiquepn.ca

**NOAA National Marine Mammal Lab**

?  
Library Bldg 4 Rm 2030 , 7600 Sand Point Way  
NE, Seattle, WA, 98115-6349 - US  
wjordan@wtcox.com

**Masaki Noguchi**

University of British Columbia  
4449 West 14th Avenue, Vancouver, B.C.  
Canada, V6R2Y2 - CA  
msk\_ngch@yahoo.com

**Northern Illinois University**

?  
Periodicals Dept., University Libraries, 1425  
West Lincoln Highway, DeKalb, IL, 60115-2868  
- US  
service@harrassowitz.de  
+49-611-530 396

**Carolyn Norton**

University of British Columbia  
? - ?  
carolyn.norton@alumni.ubc.ca

**Dr. Colin Novak**

Akoustik Engineering Limited  
515 Riverside Dr. West, Unit 1103, Windsor,  
ON, N9A 7C3 - CA  
akoustik@akoustik.ca  
(519)903-7193

**Tomasz Nowak**

?  
8542 83rd Ave, Edmonton, T6C 1B1, - CA  
now.tomek@gmail.com

**Mr. John O'Keefe**  
O'Keefe Acoustics  
10 Ridley Gardens, Toronto, Canada. , M6R  
2T8 - CA  
john@okeefeacoustics.com  
416-532-9673

**Caitlin O'Neill**  
University of Victoria  
304-1000 McKenzie Ave. , Victoria, BC, V8X  
4C8 - CA  
caitlin.v.oneill@gmail.com  
2508573214

**Alan Oldfield**  
AECOM  
5080 Commerce Blvd, Mississauga, ON L4W  
4P2, - CA  
alan.oldfield@aecom.com  
9057127058

**Donald Olynyk**  
Acoustical Consultant  
9224-90 Street Edmonton, AB T6C 3M1 - CA  
don.olynyk@shaw.ca  
7804654125

**Dr. John C. Osler**  
Defence Research and Development Canada  
Atlantic Research Center, PO Box 1012  
Dartmouth, Dartmouth, NS , B2Y 3Z7 - CA  
John.Osler@drdc-rddc.gc.ca  
902-426-3100 ext 119

**Mr. Kevin Packer**  
FFA Consultants in Acoustics & Noise Control  
Ltd.  
121 Sandpiper Lane, Chestermere, AB, T1X  
1B1, - CA  
kpacker@ffaacoustics.com  
403-922-0577

**Thomas Padois**  
?  
ETS, 1100 Notre-Dame O, Montréal, QC H3C  
1K3 - CA  
thomas.padois@etsmtl.ca

**William K.G. Palmer**  
?  
TRI-LEA-EM RR 5, 76 Sideroad 33/34  
Saugeen, Paisley, ON, N0G 2N0 , - CA  
trileaem@bmts.com

**Michel Parent**  
?  
FDI Acoustics, Suite 250, 600 Crowfoot  
Crescent NW, Calgary, AB, T3G 0B4 - CA  
mitchp@fdiacoustics.com

**Maksim Parfyonov**  
University of British Columbia  
589 Christleton Avenue, Kelowna, BC,  
V1Y5J1, - CA  
parfyonovm@gmail.com

**Richard Patching**  
?  
Patching Associates Acoustical Eng. 9, 4825  
Westwinds Dr. NE Calgary, AB T3J 4L4 - CA  
richard@patchingassociates.com

**Jamie Paterson**  
?  
45 Crawford Rose Dr., Aurora, ON, L4G 4R5 , -  
CA  
jampat@gmail.com

**Richard Joseph Peppin**  
Engineers for Change, Inc. & RION Co., Ltd.  
5012 Macon Rd, Rockville, MD 20852 - US  
peppinR@asme.org  
301-910-2813

**Aaron Peterson**  
Brown Strachan Associates  
Two Yaletown Square, 1290 Homer Street,  
Vancouver, BC, V6B 2Y5 - CA  
bsadrafts@hotmail.com  
(604) 689-0514

**Prof. Kathleen Pichora Fuller**  
University of Toronto  
Dept. of Psychology, University of Toronto ,  
3359 Mississauga Rd. N. , Mississauga, ON  
L5L 1C6 - CA  
k.pichora.fuller@utoronto.ca  
(647) 794-7560

**Howard Podolsky**  
Pyrok Inc.  
121 Sunset Rd. Mamaroneck, NY, 10543 - US  
mrpyrok@aol.com  
914-777-7770

**Linda Polka**  
McGill University  
McGill University Sch of Communication  
Sciences & Disorders 1266 Pine Ave. West  
Montréal, QC H3G 1A8 - CA  
linda.polka@mcgill.ca  
514-398-7235

**Daniel P. Prusinowski**  
Aurora Acoustical Consultants Inc., 745  
Warren Drive, East Aurora, NY 14052, USA  
Daniel P. Prusinowski, 745 Warren Drive, East  
Aurora, NY 14052, USA, - US  
dprusinowski@verizon.net  
1-716-655-2200

**Rebekka Puderbaugh**  
University of Alberta  
? - ?  
puderbau@ualberta.ca

**Dr. John David Quirt**  
Consultant  
1949 Mulberry Crescent, Ottawa, ON, K1J 8J8,  
- CA  
jdq.acoustics@bell.net  
613-745-2793

**Roberto Racca**  
JASCO Applied Sciences  
JASCO Applied Sciences Ltd., 2305 - 4464  
Markham Street , Victoria, BC, V8Z 7X8 - CA  
roberto.racca@jasco.com

**Prof. Ramani Ramakrishnan**  
Ryerson University  
27 Ashmount Crescent, Toronto, ON, pcode,  
M9R 1C8 - CA  
rramakri@ryerson.ca

**Allan Raun**  
Swallow Acoustic Consultants Ltd  
Swallow Acoustic Consultants, 23 - 366 Revus  
Ave. Mississauga,, ON, L5G 4S5, - CA  
araun@swallowacoustic.ca  
905-271-7888

**Zohreh Razavi**  
STC Acoustical Consulting LTD  
3164 Canfield Cres. North Vancouver, BC,  
V7R 2V8. - CA  
zoe@stcacoustical.com  
604-307-2006

**Dr. Eric Rehm**  
Takuvik / Université Laval  
Département de Biologie / Pavillon  
Alexandre-Vachon , 1045, av. de la Médecine,  
local 2078, Université Laval, Québec (Québec)  
G1V 0A6, Canada - CA  
eric.rehm@takuvik.ulaval.ca  
418-254-7234

**Rebecca Reich**  
WSP  
4911 Melrose Ave, Montreal, QC H3X 3P4, -  
CA  
rebecca.reich@gmail.com

**Mary Richard**  
West Caldwell Calibration Labs  
5 Marley Court , Markham ON, L3S 3M7 - CA  
wccclca@gmail.com  
905-554-8005

**Werner Richarz**  
?  
Echologics Engineering 6295 Northam Drive,  
Unit 1 Mississauga, ON L4V 1W8 - CA  
wricharz@echologics.com

**Mr. Brendan P. Rideout**  
University of Hawaii at Manoa  
2205 Hyde St., Honolulu, Hawaii, USA, 96822,  
- US  
bprideou@hawaii.edu

**Dr. Bernhard E. Riecke**  
Simon Fraser University  
School of Interactive Arts and Technology  
(SIAT), Simon Fraser University Surrey,  
250-13450 102nd Avenue , Surrey, BC V3T 0A3  
Canada, - CA  
ber1@sfu.ca

**Robertson Library**  
?  
University of PEI, 550 University Ave,  
Charlottetown, PE, C1A 4P3 - CA  
indirectcan6@caa-aca.ca

**Olivier Robin**  
Université de Sherbrooke  
Université de Sherbrooke Département de  
génie mécanique 2500, boul. de l'Université  
Sherbrooke, QC J1K 2R1 - CA  
olivier.robin@usherbrooke.ca

**Prof. Joana Rocha**  
Carleton University  
Department of Mechanical and Aerospace  
Engineering,, Carleton University,, 1125  
Colonel By Drive,, Ottawa, ON, K1S 5B6  
Canada, , - CA  
joana.rocha@carleton.ca

**Mr Alfredo Rodrigues**  
AMEC Environment & Infrastructure  
160 Traders Blvd. E., Suite 110 Mississauga,  
ON, L4Z 3K7 - CA  
al.rodrigues76@gmail.com  
(905) 568-2929 x 4317

**Ronald Roth**  
?  
Edmonton Police Service, 9620-103A Ave,  
Edmonton, AB, T5H 0H7 , - CA  
ron.roth@edmontonpolice.ca

**Jessie Roy**  
RWDI Air Inc.  
1000, 736-8th Avenue S.W., Calgary, AB, T2P  
1H4 - CA  
jessie.roy@rwdi.com  
403-232-6771 6248

**Prof. Frank A. Russo**  
Ryerson University  
Department of Psychology, Ryerson  
University, 350 Victoria Street, Toronto,  
Ontario, M5B 2K3 - CA  
russo@ryerson.ca

**Ryerson University Library**  
?  
LIB-551, 350 Victoria Street, Toronto, ON, M5B  
2K3 - CA  
indirectcan7@caa-aca.ca

**Mehrzaad Salkhordeh**  
dB Noise Reduction Inc.  
240-J Holiday Inn Drive Cambridge, ON N3C  
3X4 - CA  
mehrzaad@dbnoisereduction.com  
519-651-3330 x 220

**Katrina Scherebnyj**  
?  
471 Cabot Trail, Waterloo, Ontario, N2K 4C8, -  
CA  
kscherebnyj@gmail.com

**Ms Yasna Lisette Schifferli**  
?  
? - CA  
yasnaschifferli@gmail.com  
6476229803

**Katherine Schmirler**  
University of Alberta  
University of Alberta, Department of  
Linguistics, 3-28 Assiniboia Hall, Edmonton,  
Alberta, T6G 2E7 - CA  
schmirle@ualberta.ca

**Bruce Schneider**  
?  
CCIT Room 4073, 3359 Mississauga Rd.  
North, Mississauga, ON, L5L 1C6 , - CA  
bruce.schneider@utoronto.ca

**Stefan Schoenwald**  
Swiss Federal Laboratories for Materials  
Science and Technology  
Überlandstrasse 129 CH-8600 Dübendorf,  
Switzerland - CA  
stefan.schoenwald@empa.ch  
41 58 765 6579

**Virgini Senden**  
dBA Noise Consultants  
Henk de Haan & Virgini Senden RR1,  
site 14, box 55 Okotoks, AB T1S 1A1 - CA  
senden.virgini@gmail.com  
587 439 9980

**Cameron W. Sherry**  
?  
1128 route 203, Howick, QC, J0S 1G0 - CA  
cameronsherry4@gmail.com

**Dr Junjie Shi**  
Harbin Engineering University, China  
1005# Shuisheng Building, Harbin  
Engineering University,, Nantong Steet,  
Nangang District, Heilongjiang, 150001, - CN  
junjieshi@outlook.com

**Caroline Sigouin**  
Université du Québec à Chicoutimi  
10048, chemin de l'Orée, Rouyn-Noranda  
(Québec) J9Y 0K4, - CA  
caroline.sigouin@uqac.ca

**Davor Sikic**  
?  
Jade Acoustics Inc. 411 Confederation  
Parkway, Unit 19 Concord, ON L4K 0A8 - CA  
davor@jadeacoustics.com  
905-660-2444

**Devinder Pal Singh**  
?  
#2516, Pollard Dr, Mississauga, ON, L5C 3H1 ,  
- CA  
drdpsn@hotmail.com

**Mr. Steven Albert James Sonnenberg**  
Carleton University  
907-285 Loretta Ave. S., Ottawa, ON, K1S5A5,  
- CA  
steven.sonnenberg@carleton.ca

**Duncan Spence**  
?  
2323 Royal Windsor Dr., Mississauga, ON, L5J  
1K5 - CA  
amsales@blachford.ca  
905-823-3200

**Eduardo Stehling**  
?  
201-6433 McKay Ave, Burnaby, BC, V5H2W8, -  
CA  
edcanada14@gmail.com  
6047244540

**Robert D. Stevens**  
?  
HGC Engineering Ltd., Plaza One, Suite 203,  
2000 Argentia Rd., Mississauga, ON, L5N 1P7  
- CA  
rstevens@hgcengineering.com

**Dr. Michael R. Stinson**  
?  
National Research Council, Building U-66,  
Room 230, Ottawa, ON K1A 0R6 - CA  
mike.stinson@nrc-cnrc.gc.ca

**Mr. Andreas Strasser**  
Merlin Integrated Solutions, Inc.  
#42 - 5400 Dalhousie Dr. NW, Calgary, AB  
T3A 2B4, - CA  
astrasser@merlinis.ca  
4039704841

**Clarence Stuart**  
?  
City of Edmonton, Engineering Services  
Section, 11004 - 190 Street NW, Edmonton, AB,  
T5S 0G9 - CA  
clarence.stuart@edmonton.ca

**Jae-Hyun Sung**  
University of Alberta  
19-10646 85 Ave NW, Edmonton, AB, T6E 2K7,  
- CA  
sung@ualberta.ca

**John C Swallow**  
President, Swallow Acoustic Consultants Ltd  
Swallow Acoustical Consultants 366 Revus  
Ave., Unit 23 Mississauga, ON L5G 4S5 - CA  
jswallow@swallowacoustic.ca  
9052717888

**John Swallow**  
Swallow Acoustic Consultants Ltd.  
366 Revus Ave., Unit 23 Mississauga, ON L5G  
4S5 - CA  
info@swallowacoustic.ca

**Nicholas Sylvestre-Williams**  
Aercoustics Engineering Ltd.  
50 Ronson Drive, Suite 165 Toronto, ON M9W  
1B3 - CA  
NicholasS@aercoustics.com  
(416) 249-3361

**Omid Tamanna**  
BCIT  
1338 Talbot Court Coquitlam BC V3B 7B4 - CA  
tamomid@gmail.com  
6047276643

**Prof. Jahan Tavakkoli**  
Ryerson University  
Dept of Physics, Ryerson University, 350  
Victoria Street, Toronto, ON M5B 2K3 - CA  
jtavakkoli@ryerson.ca  
(416) 979-5000

**Technische Informationsbib. TIB**  
?  
Team Zeitschriften, Welfengarten 1 B, D-30167  
Hannover, Germany - DE  
indirectint5@caa-aca.ca

**Dr. John M. Terhune**  
?  
University of New Brunswick, Dept. of  
Biology, P.O. Box 5050, Saint John, NB, E2L  
4L5 , - CA  
terhune@unbsj.ca

**Jessica Tinianov**  
HGC Engineering  
34 Superior Ave, Toronto ON, M8V 2M6, - CA  
jtinianov@hgcengineering.com

**Cristina Tollefsen**  
Defence Research and Development Canada  
P. O. Box 1012, Dartmouth, NS B2Y 3Z7, - CA  
cristina.tollefsen@gmail.com

**Mihkel Toome**  
?  
RWDI Air Inc., 901 King St. West, Suite 400,  
Toronto, ON M5V 3H5, - CA  
mtoome@gmail.com

**Philip Tsui**  
RWDI  
617 Harrison Ave., Coquitlam, BC, V3J 3Z6, - CA  
philip.tsui@rwdi.com

**Benjamin Tucker**  
?  
Univ. of Alberta, Dept. of Linguistics, 4-32  
Assiniboia Hall, Edmonton, AB, T6G 2E7 - CA  
bvtucker@ualberta.ca

**Karen Turner**  
Protec Hearing  
Protec Hearing, Unit E, 77 Redwood Avenue,  
Winnipeg, Manitoba, R2W5J5 - CA  
protec1@mymts.net

**Dr Helen Ule**  
Akoustik Engineering Limited  
515 Riverside Dr. West; Unit 1103, Windsor,  
ON, N9A 7C3, - CA  
helen@akoustik.ca  
(519) 979-5050

**Université de Montréal**  
?  
Bibliothèque Acquisitions Périodiques, CP  
6128, Succ. Centre-Ville, Montréal, QC, H3C  
3J7 - CA  
indirectcan8@caa-aca.ca

**Svein Vagle**  
Ocean Science Division  
Institute of Ocean Sciences PO Box 6000 9860  
West Saanich Road Sidney, BC V8L 4B2 - CA  
Svein.Vagle@dfo-mpo.gc.ca  
250 363 6339

**Dr. Olivier Valentin**  
Department of Mechanical Engineering, École  
de technologie supérieure, Montréal, QC,  
Canada.  
719 6eme avenue, VERDUN, QC, H4G 3A3 - CA  
m.olivier.valentin@gmail.com  
514-885-5515

**Mr. Peter VanDelden**  
?  
650 Woodlawn Road West Guelph, ON N1K  
1B8 - CA  
peter.vandelden@rwdi.com  
519-823-1311

**Guilhem Viallet**  
École de technologie supérieure  
Ecole de technologie supérieure, département  
génie mécanique, 1100 rue Notre-Dame Ouest,  
Montreal, Québec, H3C 1K3 - CA  
guilhem.viallet.1@ens.etsmtl.ca

**Prof. Jérémie Voix**  
ÉTS, Université du Québec  
1100 Notre-Dame Ouest Montréal (QC) H3C  
1K3 - CA  
voix@caa-aca.ca  
+1 514 396-8437

**Mr. Clair W. Wakefield**  
Wakefield Acoustics Ltd.  
301-2250 Oak Bay Ave, VICTORIA, British  
Columbia, V8R 1G5 - CA  
clair@wakefieldacoustics.com  
250-370-9302

**Lina Wang**  
?  
Stantec, 200 - 325 25th Street SE Calgary AB  
T2A 7H8, , - CA  
lina.wang@stantec.com

**Graham Warner**  
?  
2396 Forbes St, Victoria BC V8R 4B6, - CA  
gwarner@uvic.ca

**Michael Wells**  
?  
Hugh Williamson Associates Inc., P.O. Box  
74056, RPO Beechwood, Ottawa, ON, K1M  
2H9, - CA  
michael@hwacoustics.ca

**Hugh Williamson**  
Hugh Williamson Associates Inc., PO Box  
74056, RPO Beechwood, Ottawa, ON, K1M  
2H9  
Hugh Williamson Assoc. Inc., PO Box 74056  
RPO Beechwood, Ottawa, ON K1M 2H9, - CA  
hugh@hwacoustics.ca  
613 747 0983

**Andrew Williamson**  
RWDI  
301-2250 Oak Bay Avenue, Victoria, BC V8R  
1G5, - CA  
andrew.williamson@rwdi.com

**Dr Douglas James Wilson**  
Imagenex Technology Corp.  
3621 Evergreen Street Port Coquitlam, BC V3B  
4X2 - CA  
dougww3@aol.com  
604 468 9406

**Mr. Chris N. Wolfe**  
?  
Vibra-Sonic Control, 4004 Gravely Street  
Burnaby, BC V5C 3T6 - CA  
chris@vibra-sonic.com  
604-294-9495

**Galen Wong**  
?  
1820 Haig Drive, Ottawa, ON, K1G 2J4, - CA  
galen.wong@gmail.com

**Mr. Richard G Wright**  
?  
12 Cimarron Grove Rise, Okotoks, AB, T1S  
2P1 - CA  
rwright5@telus.net  
403-862-3518

**Jakub Wrobel**  
?  
O2E Inc., Environmental Consultants, 399  
South Edgeware Road, Unit 5, St. Thomas,  
ON, N5P 4B8, - CA  
j.wrobel@o2e.ca

**Yihan Yanglou**  
?  
446 E 48th Ave, Vancouver BC, V5W2E5, - CA  
yanglou@ualberta.ca  
7789392553

**Mr. Victor William Young**  
Golder Associates Ltd.  
Golder Associates Ltd., 102, 2535 3rd Ave SE,  
Calgary, AB T2A 7W5, - CA  
victor\_young@golder.com  
587-434-4984

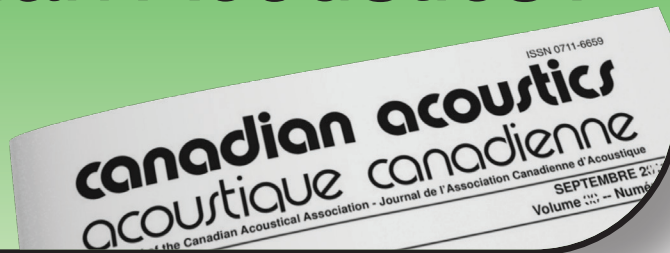
**Behrooz Yousefzadeh**  
University of British Columbia  
2054 - 6250 Applied Science Lane,, Vancouver,  
BC, V6T 1Z4 - CA  
behroozy@alumni.ubc.ca

**Pearlie Yung**  
?  
613 Dundas St. W., Unit 4, Mississauga, ON,  
L5B 0B5, - CA  
pearlie\_yung@yahoo.com

**Michel Zielinski**  
?  
51427 Range Road 270, Spruce Grove, AB, T7Y  
1E9 - CA  
sales@fabra-wall.com  
780-987-4444

**Dejan Zivkovic**  
?  
2286 Glastonbury Rd., Burlington, ON, L7P  
4C8 - CA  
dejan.zivkovic@ontario.ca

# Why publish in Canadian Acoustics?



## Because, it is...

- A respected scientific journal with a 40-year history uniquely dedicated to acoustics in Canada
- A quarterly publication in both electronic and hard-copy format, reaching a large community of experts worldwide
- An Open Access journal, with content freely available to all, 12 months from time of publication
- A better solution for fast and professional review providing authors with an efficient, fair, and constructive peer review process.

# Pourquoi publier dans Acoustique canadienne ?



## Parce que, c'est...

- Une revue respectée, forte de 40 années de publications uniquement dédiée à l'acoustique au Canada
- Une publication trimestrielle en format papier et électronique, rejoignant une large communauté d'experts à travers le monde
- Une publication "accès libre" dont le contenu est disponible à tous, 12 mois après publication
- Une alternative intéressante pour une évaluation par les pairs, fournissant aux auteurs des commentaires pertinents, objectifs et constructifs

**Application for Membership**

CAA membership is open to all individuals who have an interest in acoustics. Annual dues total \$100.00 for individual members and \$50.00 for student members. This includes a subscription to *Canadian Acoustics*, the journal of the Association, which is published 4 times/year, and voting privileges at the Annual General Meeting.

**Subscriptions to *Canadian Acoustics* or Sustaining Subscriptions**

Subscriptions to *Canadian Acoustics* are available to companies and institutions at a cost of \$100.00 per year. Many organizations choose to become benefactors of the CAA by contributing as Sustaining Subscribers, paying \$475.00 per year (no voting privileges at AGM). The list of Sustaining Subscribers is published in each issue of *Canadian Acoustics* and on the CAA website.

*Please note that online payments will be accepted at <http://jcaa.caa-aca.ca>*

**Address for subscription / membership correspondence:**

Name / Organization \_\_\_\_\_  
 Address \_\_\_\_\_  
 City/Province \_\_\_\_\_ Postal Code \_\_\_\_\_ Country \_\_\_\_\_  
 Phone \_\_\_\_\_ Fax \_\_\_\_\_ E-mail \_\_\_\_\_

**Address for mailing Canadian Acoustics, if different from above:**

Name / Organization \_\_\_\_\_  
 Address \_\_\_\_\_  
 City/Province \_\_\_\_\_ Postal Code \_\_\_\_\_ Country \_\_\_\_\_

**Areas of Interest:** (Please mark 3 maximum)

- |  |   |   |
|--|---|---|
| 1. Architectural Acoustics               | 5. Psychological / Physiological Acoustic | 9. Underwater Acoustics                   |
| 2. Engineering Acoustics / Noise Control | 6. Shock and Vibration                    | 10. Signal Processing / Numerical Methods |
| 3. Physical Acoustics / Ultrasound       | 7. Hearing Sciences                       | 11. Other                                 |
| 4. Musical Acoustics / Electro-acoustics | 8. Speech Sciences                        |   |

For student membership, please also provide:

\_\_\_\_\_  
 (University) (Faculty Member) (Signature of Faculty Member) (Date)

I have enclosed the indicated payment for:  
 CAA Membership \$ 100.00  
 CAA Student Membership \$ 50.00

Corporate Subscriptions (4 issues/yr)  
 \$100 including mailing in Canada  
 \$108 including mailing to USA,  
 \$115 including International mailing

Sustaining Subscription \$475.00  
 (4 issues/yr)

**Please note that the preferred method of payment is by credit card, online at <http://jcaa.caa-aca.ca>**

**For individuals or organizations wishing to pay by check, please register online at <http://jcaa.caa-aca.ca> and then mail your check to:**

**Executive Secretary, The Canadian Acoustical Association, PO Box 74068, Ottawa, Ontario, K1M 2H9, Canada**

### Formulaire d'adhésion

L'adhésion à l'ACA est ouverte à tous ceux qui s'intéressent à l'acoustique. La cotisation annuelle est de 100.00\$ pour les membres individuels, et de 50.00\$ pour les étudiants. Tous les membres reçoivent *'Acoustique Canadienne*, la revue de l'association. Les nouveaux abonnements reçus avant le 31 août s'appliquent à l'année courante et incluent les anciens numéros (non-épuisés) de *'Acoustique Canadienne* de cette année. Les nouveaux abonnements reçus après le 31 août s'appliquent à l'année suivante.

### Abonnement pour la revue *Acoustique Canadienne* et abonnement de soutien

Les abonnements pour la revue *Acoustique Canadienne* sont disponibles pour les compagnies et autres établissements au coût annuel de 100.00\$. Des compagnies et établissements préfèrent souvent la cotisation de membre bienfaiteur, de 475.00\$ par année, pour assister financièrement l'ACA. La liste des membres bienfaiteurs est publiée dans chaque issue de la revue *Acoustique Canadienne*. Les nouveaux abonnements reçus avant le 31 août s'appliquent à l'année courante et incluent les anciens numéros (non-épuisés) de *'Acoustique Canadienne* de cette année. Les nouveaux abonnements reçus après le 31 août s'appliquent à l'année suivante.

Notez que tous les paiements électroniques sont acceptés en ligne <http://jcaa.caa-aca.ca>

#### Pour correspondance administrative et financière:

Nom / Organisation \_\_\_\_\_  
Adresse \_\_\_\_\_  
Ville/Province \_\_\_\_\_ Code postal \_\_\_\_\_ Pays \_\_\_\_\_  
Téléphone \_\_\_\_\_ Téléc. \_\_\_\_\_ Courriel \_\_\_\_\_

#### Adresse postale pour la revue *Acoustique Canadienne*

Nom / Organisation \_\_\_\_\_  
Adresse \_\_\_\_\_  
Ville/Province \_\_\_\_\_ Code postal \_\_\_\_\_ Pays \_\_\_\_\_

#### Cocher vos champs d'intérêt: (maximum 3)

- |   |                               |  |
|---|-------------------------------|--|
| 1. Acoustique architecturale                | 5. Physio / Psycho-acoustique | 9. Acoustique sous-marine                        |
| 2. Génie acoustique / Contrôle du bruit     | 6. Chocs et vibrations        | 10. Traitement des signaux / Méthodes numériques |
| 3. Acoustique physique / Ultrasons          | 7. Audition                   | 11. Autre  |
| 4. Acoustique musicale / Électro-acoustique | 8. Parole                     |  |

Prière de remplir pour les étudiants et étudiantes:

\_\_\_\_\_  
(Université) (Nom d'un membre du corps professoral) (Signature du membre du corps professoral) (Date)

Cocher la case appropriée:

- Membre individuel 100.00 \$  
 Membre étudiant(e) 50.00 \$

Abonnement institutionnel

- 100 \$ à l'intérieur du Canada  
 108 \$ vers les États-Unis  
 115 \$ tout autre envoi international  
 Abonnement de soutien 475.00 \$  
(comprend l'abonnement à  
*L'acoustique Canadienne*)

**Merci de noter que le moyen de paiement privilégié est le paiement par carte crédit en ligne à <http://jcaa.caa-aca.ca>**

**Pour les individus ou les organisations qui préféreraient payer par chèque, l'inscription se fait en ligne à <http://jcaa.caa-aca.ca> puis le chèque peut être envoyé à :**

**Secrétaire exécutif, Association canadienne d'acoustique,  
BP 74068, Ottawa, Ontario, K1M 2H9, Canada**

## BOARD OF DIRECTORS - CONSEIL D'ADMINISTRATION

---

### OFFICERS - OFFICIERS

PRESIDENT  
PRÉSIDENT

**Frank A. Russo**  
Ryerson University  
president@caa-aca.ca

EXECUTIVE SECRETARY  
SECRÉTAIRE

**Roberto Racca**  
JASCO Applied Sciences  
secretary@caa-aca.ca

TREASURER  
TRÉSORIER

**Dalila Giusti**  
Jade Acoustics Inc.  
treasurer@caa-aca.ca

EDITOR-IN-CHIEF  
RÉDACTEUR EN CHEF

**Jérémie Voix**  
ÉTS, Université du Québec  
editor@caa-aca.ca

---

### DIRECTORS - ADMINISTRATEURS

**Alberto Behar**  
Ryerson University  
albehar31@gmail.com

**Andy Metelka**  
SVS Canada Inc.  
ametelka@cogeco.ca

**Joana Rocha**  
Carleton University  
joana.rocha@carleton.ca

**Bill Gastmeier**  
HGC Engineering  
gastmeier@rogers.com

**Hugues Nelisse**  
IRSST  
nelisse.hugues@irsst.qc.ca

**Mehrzad Salkhordeh**  
dB Noise Reduction Inc.  
mehrzaad@dbnoisereduction.com

**Bryan Gick**  
University of British Columbia  
gick@mail.ubc.ca

**Sean Pecknold**  
DRDC  
sean.pecknold@drdc-rddc.gc.ca

---

UPCOMING CONFERENCE CHAIR  
DIRECTEUR DE CONFÉRENCE (FUTURE)

**Peter VanDelden**  
conference@caa-aca.ca

PAST PRESIDENT  
PRÉSIDENT SORTANT

**Christian Giguère**  
University of Ottawa  
past-president@caa-aca.ca

WEBMASTER  
WEBMESTRE

**Philip Tsui**  
RWDI  
web@caa-aca.ca

PAST CONFERENCE CHAIR  
DIRECTEUR DE CONFÉRENCE (PASSÉE)

**Kathleen Pichora Fuller**  
University of Toronto  
k.pichora.fuller@utoronto.ca

AWARDS COORDINATOR  
COORDINATEUR DES PRIX

**Hugues Nelisse**  
IRSST  
awards-coordinator@caa-aca.ca

SOCIAL MEDIA COORDINATOR  
COORDINATEUR MÉDIA SOCIAUX

**Huiwen Goy**  
Ryerson University  
huiwen.goy@utoronto.ca

CONFERENCES COORDINATOR  
COORDINATEUR DES CONFÉRENCES

**Michael Kieft**  
mkieft@dal.ca

**Steven Albert James Sonnenberg**  
Carleton University  
steven.sonnenberg@carleton.ca

# SUSTAINING SUBSCRIBERS - ABONNÉS DE SOUTIEN

The Canadian Acoustical Association gratefully acknowledges the financial assistance of the Sustaining Subscribers listed below. Their annual donations (of \$475 or more) enable the journal to be distributed to all at a reasonable cost.

L'Association Canadienne d'Acoustique tient à témoigner sa reconnaissance à l'égard de ses Abonnés de Soutien en publiant ci-dessous leur nom et leur adresse. En amortissant les coûts de publication et de distribution, les dons annuels (de 475\$ et plus) rendent le journal accessible à tous les membres.

## **Acoustec Inc.**

J.G. Migneron - 418-496-6600  
courrier@acoustec.qc.ca  
acoustec.qc.ca

## **Aercoustics Engineering Ltd.**

Nicholas Sylvestre-Williams - (416) 249-3361  
NicholasS@aercoustics.com  
aercoustics.com

## **AMEC**

Mr. Frank Babic - 905.568.2929  
frank.babic@amec.com  
amec.com

## **Bruel & Kjaer North America Inc.**

Andrew Khoury - 514-695-8225  
andrew.khoury@bksv.com  
bksv.com

## **Dalimar Instruments Inc**

Monsieur Daniel Larose - 450-424-0033  
daniel@dalimar.ca  
www.dalimar.ca

## **dB Noise Reduction**

Mehrzaad Salkhordeh - 519-651-3330 x 220  
mehrzaad@dbnoisereduction.com  
dbnoisereduction.com

## **FFA Consultants in Acoustics and Noise Control**

Clifford Faszler - 403.508.4996  
info@ffaacoustics.com  
ffaacoustics.com

## **GHD**

Michael Masschaele -  
michael.masschaele@ghd.com  
ghd.com

## **H.L. Blachford Ltd.**

Duncan Spence - 905-823-3200  
amsales@blachford.ca  
blachford.ca

## **HGC Engineering Ltd.**

Bill Gastmeier -  
gastmeier@rogers.com  
hgcengineering.com

## **Integral DX Engineering Ltd.**

Greg Clunis - 613-761-1565  
greg@integraldxengineering.ca  
integraldxengineering.ca

## **Jade Acoustics Inc.**

Ms. Dalila Giusti - 905-660-2444  
dalila@jadeacoustics.com  
jadeacoustics.com

## **JASCO Applied Sciences (Canada) Ltd.**

Roberto Racca -  
roberto.racca@jasco.com  
jasco.com

## **Peutz & Associés**

Marc Asselineau - 33-1-45230500  
m.asselineau@peutz.fr  
peutz.fr

## **Pliteq Inc.**

Wil Byrick - 416-449-0049  
wbyrick@pliteq.com  
pliteq.com

## **Pyrok Inc.**

Howard Podolsky - 914-777-7770  
mrpyrok@aol.com  
pyrok.com

## **RION Co., Ltd**

Richard Joseph Peppin - 301-910-2813  
peppinR@asme.org  
rion-sv.com

## **ROCKFON**

Dr. Gary S. Madaras - 708.563.4548  
gary.madaras@rockfon.com  
rockfon.com

## **ROXUL**

Meghan Billingsley - 9053387600  
amanda@birchallpr.com  
roxul.com

## **RWDI AIR Inc.**

Mr. Peter VanDelden - 519-823-1311  
peter.vandelden@rwdi.com  
rwdi.com

## **Scantek Inc.**

Steve Marshall - 1-410-290-7726  
S.Marshall@scantekinc.com  
scantekinc.com

## **Swallow Acoustic Consultants**

John Swallow -  
info@swallowacoustic.ca  
swallowacoustic.ca

## **True Grit Consulting Ltd.**

Ms Ina Chomyshyn - 807-626-5640  
ina@tgcl.ca  
tgcl.ca

## **Vibra-Sonic Control**

Mr. Chris N. Wolfe - 604-294-9495  
chris@vibra-sonic.com  
vibra-sonic.com

## **Wakefield Acoustics Ltd.**

Mr. Clair W. Wakefield - 250-370-9302  
clair@wakefieldacoustics.com  
wakefieldacoustics.com

## **West Caldwell Calibration Labs**

Mary Richard - 905-554-8005  
wccalca@gmail.com  
wccalca.com